

User Manual



VX4380 256-Crosspoint Relay Matrix Module 070-9182-03



This document supports firmware version 1.00 and above.

Warning

The servicing instructions are for use by qualified personnel only. To avoid personal injury, do not perform any servicing unless you are qualified to do so. Refer to the Safety Summary prior to performing service.



Copyright © Tektronix, Inc. 1995. All rights reserved. Licensed software products are owned by Tektronix or its suppliers and are protected by United States copyright laws and international treaty provisions.

Use, duplication, or disclosure by the Government is subject to restrictions as set forth in subparagraph (c)(1)(ii) of the Rights in Technical Data and Computer Software clause at DFARS 252.227-7013, or subparagraphs (c)(1) and (2) of the Commercial Computer Software – Restricted Rights clause at FAR 52.227-19, as applicable.

Tektronix products are covered by U.S. and foreign patents, issued and pending. Information in this publication supercedes that in all previously published material. Specifications and price change privileges reserved.

Printed in the U.S.A.

Tektronix, Inc., P.O. Box 1000, Wilsonville, OR 97070–1000

TEKTRONIX and TEK are registered trademarks of Tektronix, Inc.

VXIbus is a trademark of the VXI Consortium.

SurePath and Intelliframe are registered trademarks of Tektronix, Inc.

WARRANTY

Tektronix warrants that this product will be free from defects in materials and workmanship for a period of three (3) years from the date of shipment. If any such product proves defective during this warranty period, Tektronix, at its option, either will repair the defective product without charge for parts and labor, or will provide a replacement in exchange for the defective product.

In order to obtain service under this warranty, Customer must notify Tektronix of the defect before the expiration of the warranty period and make suitable arrangements for the performance of service. Customer shall be responsible for packaging and shipping the defective product to the service center designated by Tektronix, with shipping charges prepaid. Tektronix shall pay for the return of the product to Customer if the shipment is to a location within the country in which the Tektronix service center is located. Customer shall be responsible for paying all shipping charges, duties, taxes, and any other charges for products returned to any other locations.

This warranty shall not apply to any defect, failure or damage caused by improper use or improper or inadequate maintenance and care. Tektronix shall not be obligated to furnish service under this warranty a) to repair damage resulting from attempts by personnel other than Tektronix representatives to install, repair or service the product; b) to repair damage resulting from improper use or connection to incompatible equipment; or c) to service a product that has been modified or integrated with other products when the effect of such modification or integration increases the time or difficulty of servicing the product.

THIS WARRANTY IS GIVEN BY TEKTRONIX WITH RESPECT TO THIS PRODUCT IN LIEU OF ANY OTHER WARRANTIES, EXPRESSED OR IMPLIED. TEKTRONIX AND ITS VENDORS DISCLAIM ANY IMPLIED WARRANTIES OF MERCHANTABILITY OR FITNESS FOR A PARTICULAR PURPOSE. TEKTRONIX' RESPONSIBILITY TO REPAIR OR REPLACE DEFECTIVE PRODUCTS IS THE SOLE AND EXCLUSIVE REMEDY PROVIDED TO THE CUSTOMER FOR BREACH OF THIS WARRANTY. TEKTRONIX AND ITS VENDORS WILL NOT BE LIABLE FOR ANY INDIRECT, SPECIAL, INCIDENTAL, OR CONSEQUENTIAL DAMAGES IRRESPECTIVE OF WHETHER TEKTRONIX OR THE VENDOR HAS ADVANCE NOTICE OF THE POSSIBILITY OF SUCH DAMAGES.

Table of Contents

	General Safety Summary	iii
	Preface	vii
Getting Started		
	Getting Started	1-1
	Product Description	1-1
	Accessories	1-5
	Controls and Indicators	1-5
	Configuration	1-7
	Installation	1-8
	Installation Checklist	1-10
	Functional Check	1-11
Operating Basics		
	Operating Basics	2-1
	Functional Overview	2-1
	Power-on	2-1
	Instrument I/O: VXibus Basics	2-2
Syntax and Commands		
	Command Syntax	3-1
	Functional Command Groups	3-11
	System Commands	3-11
	Module Commands	3-11
	Command Descriptions	3-15
	IEEE-488.2 Common Commands	3-53
Status and Events		
	Status and Events	4-1
	Status and Event Reporting System	4-1
	Status Byte Register	4-1
	Service Request Enable Register	4-2
	Standard Event Status Register	4-3
	Event Status Enable Register	4-4
	The Output Queue	4-4
	The System Error and Event Queue	4-4
	Status and Event Reporting Process	4-5
	Messages	4-6

Appendices

Appendix A: Specifications	A-1
Appendix B: Input/Output Connections	B-1
Appendix C: Examples	C-1
Appendix D: User Service	D-1
Appendix E: Replaceable Parts	E-1
Parts Ordering Information	E-1
Using the Replaceable Parts List	E-2

Glossary and Index

General Safety Summary

Review the following safety precautions to avoid injury and prevent damage to this product or any products connected to it.

To avoid potential hazards, use this product only as specified.

Only qualified personnel should perform service procedures.

While using this product, you may need to access other parts of the system. Read the *General Safety Summary* in other system manuals for warnings and cautions related to operating the system.

Injury Precautions

- | | |
|--------------------------------------------------|------------------------------------------------------------------------------------------------------------------------------------------------------------|
| Avoid Electric Overload | To avoid electric shock or fire hazard, do not apply a voltage to a terminal that is outside the range specified for that terminal. |
| Avoid Electric Shock | To avoid injury or loss of life, do not disconnect probes or test leads from this product while it is connected to a voltage source. |
| Do Not Operate Without Covers | To avoid electric shock or fire hazard, do not operate this product with covers or panels removed. |
| Use Proper Fuse | To avoid fire hazard, use only the fuse type and rating specified for this product. |
| Do Not Operate in Wet/Damp Conditions | To avoid electric shock, do not operate this product in wet or damp conditions. |
| Do Not Operate in an Explosive Atmosphere | To avoid injury or fire hazard, do not operate this product in an explosive atmosphere. |
| Avoid Exposed Circuitry | To avoid injury, remove jewelry such as rings, watches, and other metallic objects. Do not touch exposed connections and components when power is present. |

Product Damage Precautions

- | | |
|-----------------------------------|-------------------------------------------------------------|
| Provide Proper Ventilation | To prevent product overheating, provide proper ventilation. |
|-----------------------------------|-------------------------------------------------------------|

Do Not Operate With Suspected Failures

If you suspect there is damage to this product, have it inspected by qualified service personnel.

Safety Terms and Symbols

Terms in This Manual

These terms may appear in this manual:



WARNING. Warning statements identify conditions or practices that could result in injury or loss of life.



CAUTION. Caution statements identify conditions or practices that could result in damage to this product or other property.

Terms on the Product

These terms may appear on the product:

DANGER indicates an injury hazard immediately accessible as you read the marking.

WARNING indicates an injury hazard not immediately accessible as you read the marking.

CAUTION indicates a hazard to property including the product.

Symbols on the Product

The following symbols may appear on the product:



DANGER
High Voltage



Protective Ground
(Earth) Terminal



ATTENTION
Refer to Manual



Double
Insulated

Certifications and Compliances

Safety Certification of Plug-in or VXI Modules

For modules (plug-in or VXI) that are safety certified by Underwriters Laboratories, UL Listing applies only when the module is installed in a UL Listed product.

For modules (plug-in or VXI) that have cUL or CSA approval, the approval applies only when the module is installed in a cUL or CSA approved product.

Compliances Consult the product specifications for Overvoltage Category, and Safety Class.

Overvoltage Category The following defines overvoltage categories:

CAT III: Distribution level mains, fixed installation.

CAT II: Local level mains, appliances, portable equipment

CAT I: Signal level, special equipment or parts of equipment, telecommunication, electronics

Preface

This manual assumes you are familiar with VXIbus instruments and operation and with the purpose and function of this instrument.

Please read and follow all instructions for installation and configuration. Use the Installation Checklist to ensure proper installation and to record your initial settings.

The *Operating Basics* section gives a summary of VXIbus operation and presents an overview of the operation of this instrument.

The *Syntax and Commands* section provides a summary of all the commands followed by detailed descriptions of each command.

The *Status and Events* section contains an explanation of the Status and Event Reporting System and lists the system messages. *Appendix C: Examples* contains example programs that demonstrate the programmable features of this instrument.

You may also want to keep the *Reference Guide* by the instrument.

Conventions

The names of all switches, controls, and indicators appear in this manual exactly as they appear on the instrument.

Specific conventions for programming are given in the sections *Syntax and Commands* and *Appendix C: Examples*.



Getting Started

Getting Started

This section begins with a brief description of the VX4380 256-Crosspoint Relay Matrix Module, and explains how to configure and install the module in a VXIbus mainframe. The quick functional check, also included in this section, assures that the instrument operates properly.

Product Description

The VX4380 256-Crosspoint Relay Matrix Module is a printed circuit board assembly for use in a mainframe conforming to the VXIbus Specification. The VX4380 provides four 4×16 2-wire matrix sections. Each section can be configured to connect either the four rows or the sixteen columns to the section above or below it to produce up to a 16×16 2-wire matrix or a 4×64 2-wire matrix. The VX4380 provides the following features:

- high density single slot VXI relay matrix module with four 2-wire matrices
- 2 A switching maximum current per contact
- 220 VDC, 250 VAC maximum switching voltage per contact
- 60 W, 125 VA maximum switching power per contact
- latching relays for low-power, low-noise operation
- two 160-pin DIN front panel connectors
- low-cost VXI local bus slave interface
- Option 01 – this option enables the VX4380 to control up to 11 additional relay modules from the Tektronix family of relay modules. These modules are controlled via the VXI P2 local bus.
- > 15 MHz bandwidth (– 3 dB) for 4×16 2-wire matrix
- > 15 MHz bandwidth (– 3 dB) for 16×16 2-wire matrix

User control of the VX4380 is achieved by installing the Option 01 VXI Interface daughter board. This daughter board may be installed on the VX4380 or on another Tektronix compatible relay module which is installed in a VXI chassis slot to the left of the VX4380. The Option 01 daughter board acts as a VXI servant to a VXI bus commander. The VXI bus commander sends SCPI compatible commands to the Option 01 daughter board using VXI word serial protocol. The Option 01 daughter board in turn controls the VX4380 on which it is installed and controls additional relay modules installed in adjacent slots to its right via the VXI P2 local bus. The daughter board is capable of controlling from

one to 12 relay modules including members of the SurePath™ family of relay switching modules and VX4372 and VX4374 Scanner Slave modules. In this document, these modules will be referred to as “local bus slaves.”

The Option 01 VXI Interface Module includes the following features:

- CPU:

 - Zilog Z88C00 Microcontroller with 20 MHz clock

 - 64 Kbyte of EPROM and 32 Kbyte of RAM

- VXI Interface:

 - VXI Rev 1.4 Message Based Device

 - Supports Fast Handshake word serial protocol data transfers

 - IEEE-488.2 device

 - Logical Address selectable with two rotary hexadecimal switches

 - Interrupter level selectable with a rotary hexadecimal switch. Selects one of seven levels or disables interrupt generation

 - Command programmable control of one to eight VXI TTL trigger

 - Command programmable monitoring of one of eight VXI TTL triggers

The Local Bus Interface provides serial I/O interface for control of VX4372 and VX4374 Scanner Slave and SurePath™ relay modules, monitors the power fuses of all local bus slave modules that it controls, and provides a serial input interface to identify each local bus slave that it controls.

As part of the self test, SurePath™ modules automatically verify the control logic every time a relay operation is performed.

Figure 1–1 shows a functional block diagram of the VX4380. Figure 1–2 shows a typical SurePath™ configuration.

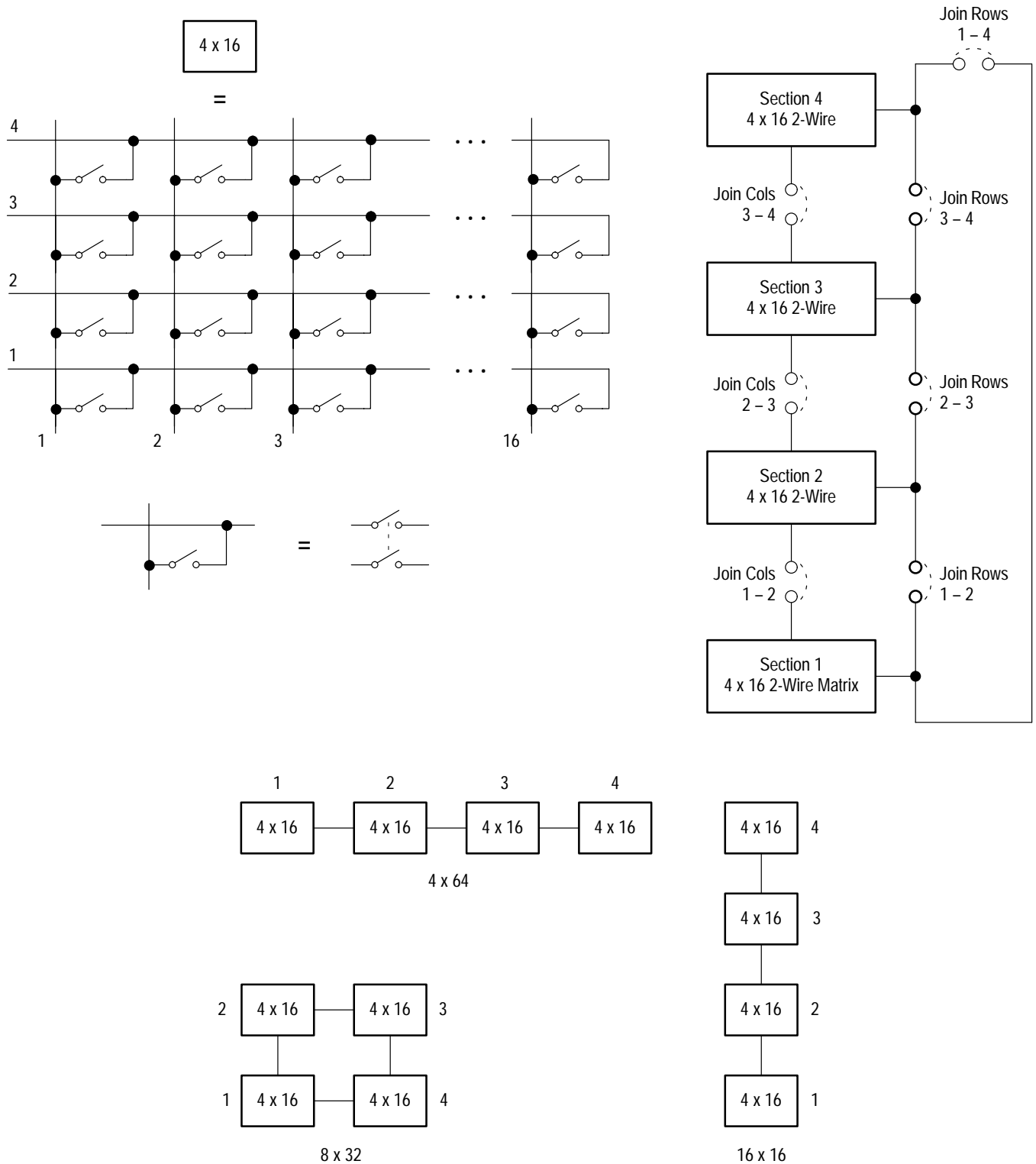

Figure 1-1: VX4380 Functional Block Diagram

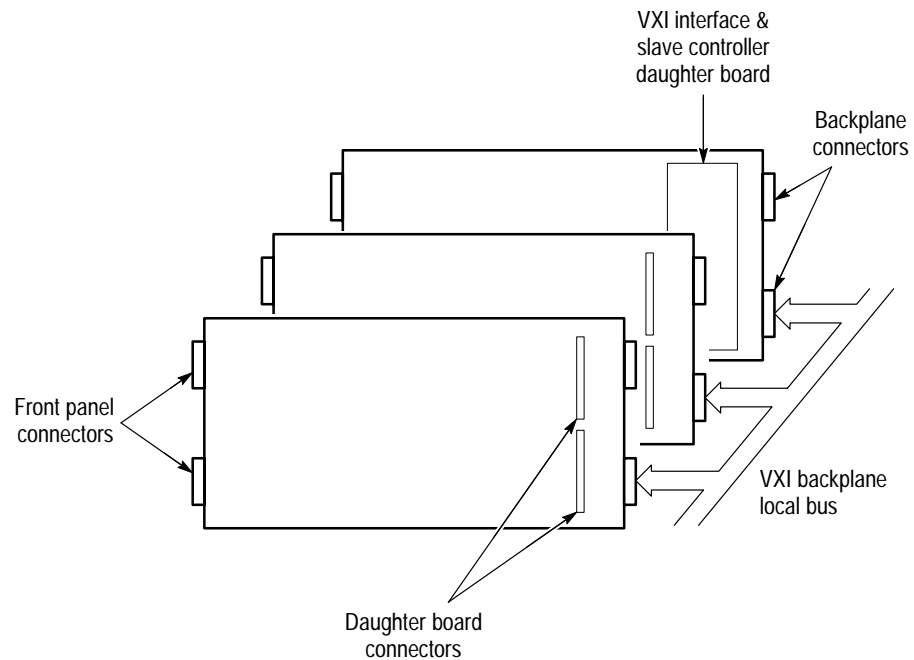

Figure 1-2: Typical SurePath Configuration

Fuses The VX4380 Module has one 10 A fast-acting fuse on the +5 V line.

Each relay module that the Option 01 Module controls has a fuse that limits the amount of current that the module can draw from the VXI backplane +5 V power pins. This fuse protects the module in case of an accidental shorting of the power bus or any other situation where excessive current might be drawn.

The Option 01 Module monitors the state of the fuses of each of the relay modules that it controls. If a fuse opens on one of these modules, the Option 01 Module will assert SYSFAIL* on the VXIbus.

If the +5 V fuse on the module on which the Option 01 Module is installed opens, the VXIbus Resource Manager will be unable to assert SYSFAIL INHIBIT on the Option 01 to disable SYSFAIL*.

If a +5 V fuse opens, remove the fault before replacing the fuse. Replacement fuse information is given in the *Specifications* section of the user manual for the appropriate relay module.

LEDs The following LEDs are visible at the top of the VX4380 Module's front panel to indicate the status of the module's operation (see Figure 1–5).

Power LED indicates power is applied to the module

Failed LED indicates the module is in the FAILED state

BITE (Built-in Test Equipment) Built-in Test Equipment (BITE) is provided by extensive self tests that are automatically invoked on power-on and can also be invoked on command. Circuitry tested includes the CPU and all memory, and the relay control circuitry on each relay module controlled by the Option 01.

Accessories

Table 1–1 lists the standard accessories included with the VX4380.

Table 1–1: Standard Accessories

Accessory	Part Number
VX4380 User Manual	070-9182-XX
VX4380 Reference	070-9202-XX

Table 1–2 lists the options available for the VX4380.

Table 1–2: Options

Option	Part Number
01 VXI Interface Kit	040-1510-XX

Controls and Indicators

The following controls are provided to select the functions of the VX4380 operating environment. Figures 1–3 and 1–4 illustrate the physical location of these controls and indicators.

Switches The Logical Address switches and VMEbus Interrupt Level Select switch must be correctly set to insure proper operation. See *Configuration* for details on how to set the switches.

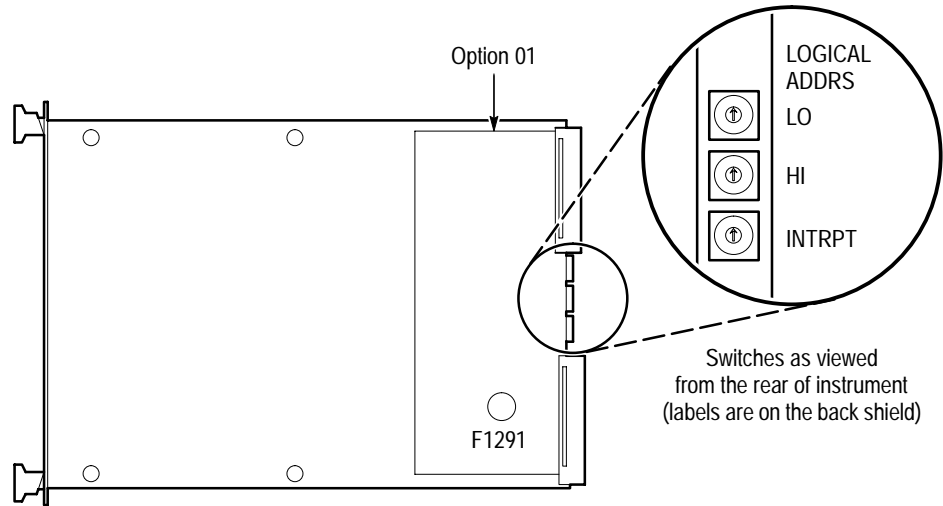

Figure 1-3: VX4380 Connectors, Indicators, and Switch Locations

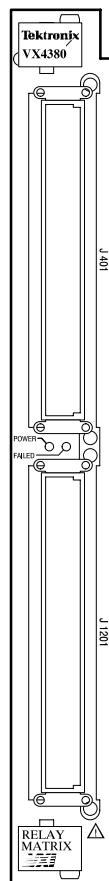

Figure 1-4: VX4380 Front Panel

Configuration

The following switches must be correctly set to ensure proper operation. Refer to Figure 1–3 for their physical locations.

Logical Address Switches

Each functional module in a VXibus System must be assigned a unique logical address, from 1 to decimal 255 (hexadecimal FF). The base VMEbus address of the VX4380 is set to a value between 1 and hexadecimal FF (FF_{16}) by two hexadecimal rotary switches. Align the desired switch position with the arrow on the module shield.

The physical address of the instrument is on a 64 byte boundary. If the Logical Address switch representing the most significant digit (LA-HI) of the logical address is set to position X and the switch representing the least significant digit (LA-LO) of the logical address is set to position Y, then the base physical address of the VX4380 will be $[(40_{16} \times XY_{16}) + C000_{16}]$. For example:

Base Physical Address				
L.A.	HI	LO	decimal	hex
A_{16}	0_{16}	A_{16}	$(64 * 10) + 49152 = 49792$	$(40_{16} * A_{16}) + C000_{16} = C280_{16}$
15_{16}	1_{16}	5_{16}	$(64 * 21) + 49152 = 50496$	$(40_{16} * 15_{16}) + C000_{16} = C540_{16}$

LA. is the Logical Address

IEEE-488 Address

In order to use and program the VX4380 Module in an IEEE-488 environment you must know the IEEE-488 address of the module. Different manufacturers of IEEE-488 interface devices might have different algorithms for equating a logical address with an IEEE-488 address. Consult the operating manual of the IEEE-488 Interface Module being used.

VMEbus Interrupt Level Select Switch

Each function module in a VXibus System can generate an interrupt at a specified level on the VMEbus to request service from the interrupt handler located on its commander. Set the interrupt level to the same level as the interrupt handler on that commander. The VMEbus interrupt level on which the VX4380 Module generates interrupts is set by a rotary switch. Align the desired switch position with the arrow on the module shield.

Valid VMEbus Interrupt Level Select switch settings are one through seven, with setting one equivalent to level one, and so on. The level chosen should be the same as the level set on the VX4380 interrupt handler, typically the module commander. Setting the switch to zero or eight will disable the module interrupts. Do not use switch settings nine through f.

Interrupts are used by the module to return VXIbus Protocol Events to the module commander. Refer to the *Operating Basics* section for more information on interrupts. The VXIbus Protocol Events supported by the module are listed in *Appendix A: Specifications*.

Installation

This section describes how to install the VX4380.

Tools Required

A slotted screwdriver set is required for proper installation.

Requirements and Cautions

The VX4380 Module is a C-size VXIbus instrument module and therefore may be installed in any C- or D-size VXIbus mainframe slot other than slot 0. To install the module in a D-size mainframe, consult the operating manual for the mainframe. Refer to *Configuration* for information on selecting and setting the Logical Address switch of the module. This switch defines the programming address of your module. To avoid confusion, it is recommended that the slot number and the logical address be the same.

NOTE. *Note that there are two printed ejector handles on the card. To avoid installing the card incorrectly, make sure the ejector marked “VX4380” is at the top.*

Verify that the mainframe is able to provide adequate cooling and power with this module installed. Refer to the mainframe Operating Manual for instructions.

If the VX4380 is used in a Tektronix mainframe, all VX4380 cooling requirements are met

If the VX4380 is inserted in a slot with any empty slots to the left of the module, the VME daisy-chain jumpers must be installed on the backplane in order for the VXI Module to operate properly. Check the manual of the mainframe being used for jumpering instructions. Jumpers are not necessary for autoconfiguring backplane designs.

Installation Procedure

Follow these steps to install the VX4380. If the module has Option 01, first refer to the Option 01 User Manual for instructions on mounting the option.



CAUTION. *The VX4380 Module is a piece of electronic equipment and therefore has some susceptibility to electrostatic damage (ESD). ESD precautions must be taken whenever the module is handled.*

1. Record the revision level, serial number (located on the label on the shield of the VX4380), and switch settings on the *Installation Checklist*.
2. Verify that the switches are set to the correct values. Refer to *Configuration* for more information on setting switches.
3. Make sure that the mainframe power is off.
4. Insert the module into one of the instrument slots of the mainframe (see Figure 1-5).
5. Cable Installation: Use the correct cable to interface between the module I/O connector and the Unit Under Test (UUT). The recommended cable is listed in *Appendix A: Specifications*.

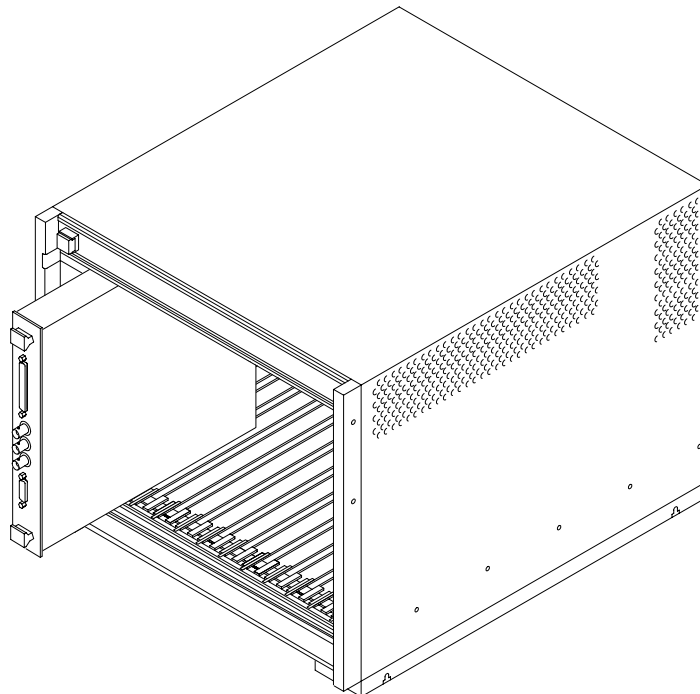

Figure 1-5: Module Installation

Installation Checklist

Installation parameters will vary depending on the mainframe being used. Be sure to consult the mainframe operating manual before installing and operating the module.

Revision Level: _____

Serial No.: _____

Mainframe Slot Number: _____

Switch Settings: _____

VXibus Logical Address Switch: _____

Interrupt Level Select Switch: _____

Cable Installed (if any): _____

Performed by: _____ Date: _____

Functional Check

In addition to the self tests, you can also perform an operational check of the VX4380.

Self Test The VX4380 256-Crosspoint Relay Matrix Module executes a self test at power-on, on direction of a VXIbus hard or soft reset condition, or on command. The power-on self test consists of an interface self test and an instrument self test. The self test requested by command performs only the instrument self test. A VXIbus hard reset occurs when another device, such as the VXIbus Resource Manager, asserts the backplane line SYSRESET*. A VXIbus soft reset occurs when another device, such as the VX4380 commander, sets the Reset bit in the VX4380 Control register.

During power-on, or a hard or soft reset, the following actions take place:

1. The SYSFAIL* (VME system-failure) line is set active, indicating that the module is executing a self test, and the Failed LED is lighted. For a soft reset, SYSFAIL* is set. All Tektronix commanders will simultaneously set SYSFAIL INHIBIT to prevent the resource manager from prematurely reporting the failure of a card.
2. On completion of the interface self test, SYSFAIL* is de-asserted. If the test fails, the SYSFAIL* line remains active. If the interface self test passed, the SYSFAIL* line is released, and the module enters the VXIbus PASSED state (ready for normal operation). If it failed, the module enters the VXIbus FAILED state.
3. The instrument self test, as described in the *TST? command description, is then executed. This tests the Option 01 VXI Interface daughter board and any relay modules under its control. If the self test fails, the module makes an internal record of the failure(s) that occur.

The default condition of the Option 01 Module after the completion of power-on self test is as follows:

All relays on modules controlled by the Option 01 (except VX4320 Modules) are set to the open position.

You can run the self test at any time during normal operation by using the *TST? command. At the end of a self test initiated by this command, the module is restored to its pre-test state.

During a commanded self test:

1. SYSFAIL* is not asserted.
2. The module executes the same instrument self test as is executed upon power on.
3. When the self test is completed, the modules controlled by the Option 01 are restored to their pre-test state.

**Operational
Check**

An operational check of the VX4380 may be performed by checking the continuity of the switch closures using an ohmmeter or a test light.

When equipped with the Option 01 VXI Interface, the commands

```
ROUTE:OPEN:ALL M1
```

will open all of the relay paths. All relays on the VX4380 will also be opened automatically on power-on. Figure 1–1 VX4380 Functional Block Diagram shows the configuration of the VX4380 with all paths open. Refer to *Appendix B: Input/Output Connections* for the connector pinouts and the Functional Block Diagram. Use a continuity tester to verify that all rows are open to all columns.

```
ROUTE:CLOSE (@M1(1!1!1))
```

Will close the 2-wire switch path from row 1 of section 1 to column 1 of section 1 (Row01Lo of Section 1 to Col01Lo of Section 1, and Row01Hi of Section 1 to Col01Hi of Section 1). Check the continuity. Be careful to prevent damage to the pins of the front panel connectors.

Note that true measurement of the resistance of the path requires a high-resolution instrument and special procedures which are beyond the scope of this check.

Use the commands

```
ROUTE:OPEN:ALL M1
```

and

```
ROUTE:CLOSE (@M1(1!2!1))
```

to open the previous path and close the 2-wire switch path from row 1 of section 1 to column 2 of section 1. Check for continuity of the two paths.

Use the commands

```
ROUTE:OPEN:ALL M1
```

and

```
ROUTE:CLOSE (@M1(r!c!s))
```

incrementing *r* (the row number) from 1 through 4 for each value of *c* and *s* while incrementing *c* (the column number) from 1 through 16 for each value of *s* (the section number) from 1 through 4 to close the two-wire switch path from row *r* to column *c* of each section *s*. Check for continuity of the two paths each time.

By testing in this manner, it can be verified that the module is operational.

SYSFAIL* Operation

SYSFAIL* becomes active during power-on, hard or soft reset, or self test, or if the module loses any of its power voltages. When the mainframe Resource Manager detects SYSFAIL* set, it will attempt to inhibit the line. This causes the VX4380 256-Crosspoint Relay Matrix Module to deactivate SYSFAIL* except when +5 V power is lost on the relay module on which it is installed.



Operating Basics

Operating Basics

The VX4380 256-Crosspoint Relay Matrix Module is a VXIbus message-based instrument and communicates using the VXIbus Word Serial Protocol. The module is programmed by issuing ASCII characters from the system controller to the VX4380 via the module VXIbus commander and the VXIbus mainframe backplane. Refer to the manual for the VXIbus device that will be the VX4380 Module commander for details on the operation of that device.

If the module commander is a Tektronix IEEE-488 Interface Module, refer to the operating manual for the module and *Appendix C: Examples* in this manual for information on how the system controller communicates with the commander being used.

Functional Overview

The VX4380 256-Crosspoint Relay Matrix Module provides four 4×16 2-wire matrix sections. Each section can be configured to connect either the four rows or the sixteen columns to the section above or below it to produce up to a 16×16 2-wire matrix or a 4×64 2-wire matrix.

Power-on

The instrument runs its self test and is ready for programming five seconds after power-on. The VXIbus Resource Manager can add an additional delay. The Power LED of each relay module controlled by the Option 01 will be on. The Failed LED on each of these modules will be off. The default condition of the module after power-on is listed in the *RST command description. Self-test failures are described in the *TST command description.

The format and syntax for the command strings are described in the *Command Syntax* section. A complete description of each command in alphabetical order is in the *Command Descriptions* section.

Instrument I/O: VXIbus Basics

NOTE. *If the user's mainframe has other manufacturers' computer boards operating in the role of VXIbus foreign devices, the assertion of BERR* (as defined by the VXIbus Specification) may cause operating problems on these boards.*

The Option 01 Module installed on a switching module is a C-size single slot VXIbus Message-Based Word Serial instrument. It uses the A16, D16 VME interface available on the backplane P1 connector and does not require any A24 or A32 address space. The module is a D16 interrupter.

The Option 01 is neither a VXIbus commander nor a VMEbus master; therefore it does not have a VXIbus Signal register. The Option 01 is a VXIbus message-based servant.

The module supports the Normal Transfer Mode of the VXIbus using the Write Ready, Read Ready, Data In Ready (DIR), and Data Out Ready (DOR) bits of the module Response register.

A Normal Transfer Mode read of the Option 01 proceeds as follows:

1. The commander reads the Option 01 Response register and checks if the Write Ready and DOR bits are true. If they are, the commander proceeds to the next step. If not, the commander continues to poll these bits until they become true.
2. The commander writes the Byte Request command (hexadecimal 0DEFF) to the Data Low register of the Option 01.
3. The commander reads the Option 01 Response register and checks if the Read Ready and DOR bits are true. If they are, the commander proceeds to the next step. If not, the commander continues to poll these bits until they become true.
4. The commander reads the Option 01 Data Low register.

A Normal Transfer Mode write to the Option 01 proceeds as follows:

1. The commander reads the Option 01 Response register and checks if the Write Ready and DIR bits are true. If they are, the commander proceeds to the next step. If not, the commander continues to poll the Write Ready and DIR bits until they are true.
2. The commander writes the Byte Available command which contains the data (hexadecimal 0BCXX or 0BDXX, depending on the End bit) to the Data Low register of the Option 01.

The module also supports the Fast Handshake Mode during readback. In this mode, the module is capable of transferring data at optimal backplane speed without needing the commander to test any of the handshake bits. The Option 01 asserts BERR* to switch from Fast Handshake Mode to Normal Transfer Mode, per VXI Specification. The Option 01 Read Ready, Write Ready, DIR and DOR bits react properly, in case the commander does not support the Fast Handshake Mode.

A Fast Handshake Transfer Mode read of the Option 01 proceeds as follows:

1. The commander writes the Byte Request command (hexadecimal 0DEFF) to the Option 01 Data Low register.
2. The commander reads the Option 01 Data Low register.

A Fast Handshake Transfer Mode write of the Option 01 proceeds as follows:

The commander writes the Byte Available command which contains the data (hexadecimal 0BCXX or 0BDXX, depending on the End bit) to the Data Low register of the Option 01. The commander may immediately write another Byte Available command without having to check the Response register.

The module has no registers beyond those defined for VXIbus message based devices. All communications with the module are through the Data Low register, the Response register, or the VXIbus interrupt cycle. Any attempt by another module to read or write to any undefined location of the Option 01 address space may cause incorrect operation of the module.

As with all VXIbus devices, the Option 01 has registers located within a 64 byte block in the A16 address space. The base address of the Option 01 device registers is determined by the device unique logical address and can be calculated as follows:

$$\text{Base Address} = V_{16} * 40_{16} + C000_{16}$$

where V is the device logical address as set by the Logical Address switches.

Configuration Registers

Table 2–1 lists the Configuration registers and a complete description of each register. The offset is relative to the module base address.

Table 2–1: Register Definitions

Register	Address (hexadecimal)	Type	Value (Bits 15-0)
ID Register	0000	RO	1011 1111 1111 1101 (hexadecimal BFFD)
Device Type	0002	RO	See Device Type definition below
Status	0004	R	Defined by state of interface

Table 2–1: Register Definitions (Cont.)

Register	Address (hexadecimal)	Type	Value (Bits 15-0)
Control	0004	W	Defined by state of interface
Offset	0006	WO	Not used
Protocol	0008	RO	1111 0111 1111 1111 (hexadecimal F7FF)
Response	000A	RO	Defined by state of the interface
Data High	000C		Not used
Data Low	000E	W	Not fixed; command-dependent
Data Low	000E	R	Not fixed; command-dependent

RO is Read Only
WO is Write Only
R is Read
W is Write

The Register Bit definitions are listed in Tables 2–2 and 2–3.

Table 2–2: Register Bit Definitions

Register	Bit Definition
ID	hexadecimal BFFD
Protocol	hexadecimal F7FF

The contents of the Device register of the Option 01 Module depends on the model number of the relay module that it is installed on, as shown in Table 2–3.

Table 2–3: Device Register Bit Definitions

Relay Model No.	Device Register Contents
VX4320	hexadecimal FCBF
VX4330	hexadecimal F6B5
VX4350	hexadecimal F6A1
VX4380	hexadecimal F683



Syntax and Commands

Command Syntax

Command protocol and syntax for the VX4380 Module are as follows:

- A command string consists of a string of ASCII-encoded characters terminated by a <program message terminator>. The <program message terminator> is optional white space, followed by any one of the following command terminations:

- a line feed <LF> or new line <NL> character (hexadecimal 0A, decimal 10)

- the END bit set

- the END bit with a line feed <LF> or new line <NL>

The command string is buffered until the terminator is encountered, at which time the entire string is processed.

- In addition to terminating a command, the semi-colon character directs the SCPI command parser to interpret the next command with the assumption that all characters up to and including the last colon in the previous command have just been parsed. In the following example, the Option 01 is installed on a VX4380 Module. Two additional VX4380 Modules are installed in consecutive slots to the right of the first VX4380. Under these conditions, the commands

- ```
route:open:all m1<LF>
```

- ```
route:open:all m2<LF>
```

- ```
route:open:all m3<LF>
```

cause all relays on all three VX4380 Modules to open. Note that each of these commands is terminated by a line feed. An equivalent method of sending these commands using the semi-colon character as a terminator is

- ```
route:open:all m1; all m2; all m3<LF>
```

After a line feed or END bit is used to terminate a command, the parser no longer makes the assumption described above. Thus, after the command

- ```
route:open:all m1; all m2<LF>
```

is parsed, the command

- ```
all m2<LF>
```

is no longer valid.

In the next example, the Option 01 is installed on a VX4330 Module. Two additional VX4330 Modules are installed in consecutive slots to the right of the first VX4330. The commands

```
route:configure:join m1,(1:6)<LF>
```

```
route:configure:join m2,(1:2)<LF>
```

```
route:configure:join m3,(1:4)<LF>
```

connect the commons of sections 1 through 6 on the first VX4330, sections 1 and 2 on the second VX4330 and sections 1 through 4 on the third VX4330. An equivalent way to send these commands using the semi-colon as a terminator is

```
route:configure:join m1,(1:6); join m2,(1:2); join  
m3(1:4)<LF>
```

Note that <LF> in these examples represents a single line feed character.

- White space characters can be used to make a command string more readable. These characters are ASCII-encoded bytes in the range hexadecimal 00-09 and 0B-20 (decimal 0-9 and 11-32). This range includes the ASCII control characters and the space, but excludes the line feed <NL>. White space characters are ignored when legally encountered in a command string. White space is allowed anywhere in a command string, except for the following:

Within a program mnemonic (for example RO UTE)

Around a colon (:) mnemonic separator (for example ROUTE: CLOSE or ROUTE :CLOSE)

Between a mnemonic and a (?) (for example CLOSE ?)

Following an asterisk (*) (for example * STB?)

Within a number (for example 12 34)

Within a module name specified in a [ROUTE:]MODUle[:DEFine] command (for example ROUTE:MODULE:DEFINE RFM UX, 1).

At least one white space character is required between a command/query header and its associated arguments. For example in the command

```
route:configure:join m1,(1:6)
```

the command header is the string “route:configure:join”. The arguments associated with this command are the module name “m1” and the section list “(1:6)”. At least one white space character must be sent before the first argument.

In the query

```
route:close? (@m1(1:64))
```

the query header is the string “route:close?”. The argument associated with this query is the channel list “(@m1(1:64))”. At least one white space character must be sent before the channel list argument.

- All characters in a command can be sent in either upper or lower case form.
- Multiple data parameters passed by a command are separated by a comma (,).
- A question mark (?) following a command indicates that a response will be returned. All responses from the module are terminated with a carriage return <CR> and a line feed <LF> (hexadecimal 0A) character.
- In the command descriptions, the following special characters are used. Except for the colon (:), these characters are not part of the command and should not be sent. If an optional field is omitted, the default for the command is applied.

[] Brackets indicate an optional field

| A bar indicates a logical OR choice

: A colon is used to separate command fields

< > Field indicator

Syntax Example

Capital letters indicate the minimum required characters which need to be sent. Lower case letters are optional. For example, the syntax of the trigger source command is given as

```
TRIGger[:SEquence]:SOURce BUS | HOLD | IMMEDIATE | TTLTrg<n>
```

Each of the following is a valid form of this command:

```
trigger:sequence:source bus
```

```
trig:seq:sour hold
```

```
Trig:SOUR IMM
```

```
Trig:Sour TTLTRG1
```

```
Trig:Sour TTLT1
```

```
Trigger:Source Immediate
```

**SCPI/IEEE 488.2
Command Elements**

The definition of elements used in SCPI/IEEE 488.2 commands and command descriptions is as follows:

<NR1> ASCII integer representation of a decimal number.

<NRf> ASCII integer, fixed point or floating point representation of a decimal number.

<module_name> A user-defined ASCII string to be associated with the local bus address of a relay module. <module_name> strings must start with a letter and may consist of alphanumeric characters, underscores, and digits. The maximum length of a <module_name> is 12 characters.

<channel_spec> One or more <NR1> ASCII strings separated by “!” characters that specify a relay on a relay module. The format of a <channel_spec> field for each of the SurePath relay modules is:

- VX4320 RF Multiplexer: <NR1> ! <NR1>

The range of the first <NRf> field is 1 to 4. This field specifies a relay within one of the sections of the VX4320. The range of the second <NRf> field is 1 to 8. This field specifies a section of the VX4320. A one-dimensional <channel_spec> may also be used to specify a channel on a VX4320 Module. The one-dimensional <channel_spec> is given by the formula:

$$((\text{section} - 1) \times 4) + \text{relay}.$$

where variables “section” and “relay” are section and relay numbers specified in a two-dimensional <channel_spec>.

- VX4330 Scanner/Multiplexer: <NR1> ! <NR1>

The first <NR1> field specifies a relay within the specified section. The range of this <NR1> field depends on the current configuration of the section of the VX4330 specified in the second <NR1> field. The range of the second <NR1> field is 1 to 6. This field specifies a section of the VX4330.

1 – 10	4-wire
1 – 20	4-wire independent
1 – 20	2-wire
1 – 40	1-wire

- VX4350 General Purpose Switching module: <NR1>

The range of this field is 1 to 64. It specifies one of 64 relays on the VX4350.

- VX4380 Matrix: <NR1> ! <NR1> ! <NR1>

The range of the first <NR1> field is 1 to 4. It specifies the row of a relay in one of the sections of the VX4380. The range of the second <NR1> field is 1 to 16. It specifies the column of a relay in one of the sections of the VX4380. The range of the third <NR1> field is 1 to 4. It specifies a section of the VX4380. A one dimensional <channel_spec> may also be used to specify a channel on a VX4380 Module. The one dimensional <channel_spec> is given by the formula:

$$((\text{section} - 1) \times 64) + ((\text{row} - 1) \times 16) + \text{column}$$

where variables “section” and “row” and “column” are section, row, and column numbers specified in a three-dimensional <channel_spec>.

Channel_list A list of channel numbers on one or more relay modules.

The limits on the channel numbers in a <channel_list> depend on the model number of the relay module(s) specified in the <channel_list>. The syntax of a <channel_list> is shown in the following diagram:

<channel_range>

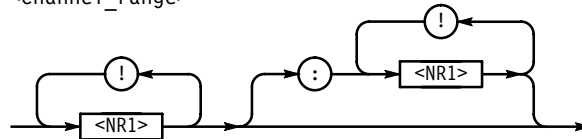

<channel_list>

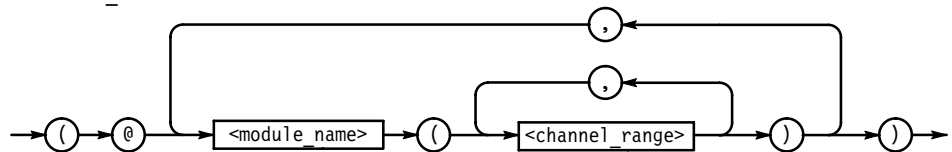

A module_name is an ASCII string that has been associated with a relay module in a ROUTE:MODULE:DEFINE command. A channel_range may consist of a single <channel_spec> or a range of <channel_spec>s. A range of <channel_spec>s is indicated by two <channel_spec>s separated by a colon (:). A <channel_spec> may have one, two or three dimensions depending on the architecture of the relay module it applies to.

The following are examples of valid <channel_list>s for Tektronix VX4320, VX4330, VX4350, VX4372, VX4374, and VX4380 relay modules. In these examples it is assumed that the Option 01 is installed on a VX4320 Module. A VX4330, VX4350, VX4372, VX4374, and VX4380 are installed in consecutive slots to the right of the VX4320. The default module names for the VX4320, VX4330, VX4350, VX4372, VX4374 and VX4380 in this example are m1, m2, m3, m4, m5, and m6 respectively. These module names may be overridden by specifying new module names with the [ROUte:]MODUle[DEFine] command. It is also assumed in these examples that all sections on the VX4330 Module have been configured as 10-to-1 4-wire scanners.

<channel_list>	Channels Specified
(@m1(1!2))	Channel number 1 of section 2 on the VX4320 Module.
(@m1(4!1,3!8))	Channel number 4 in section 1 and relay number 3 in section 8 of the VX4320 Module.
(@m1(4!1:4!8))	Channel number 4 in sections 1 through 8 on the VX4320 Module.
(@m1(4!1,4!2,4!3,4!4,4!5,4!6,4!7,4!8))	Channel number 4 in sections 1 through 8 on the VX4320 Module.
(@m2(1!6))	Channel 1 in section 6 of the VX4330 Module.
(@m2(1!1:10!6))	All channels on the VX4330 Module in the following order: 1!1, 1!2, 1!3, 1!4, 1!5, 1!6, 2!1, 2!2, 2!3, 2!4, 2!5, 2!6, ... , 10!1, 10!2, 10!3, 10!4, 10!5, 10!6.
(@m2(1!3:10!3))	All 10 channels in section 3 of the VX4330.
(@m3(1:64))	All 64 channels on the VX4350
(@m3(1,2,3,10,11,20:13))	Channels 1, 2, 3, 10, 11, and 20 through 13 on the VX4350.
(@m4(1!2))	Channel 1 in section 2 of the VX4372.
(@m5(3!1))	Channel 3 in section 1 of the VX4374.
(@m6(1!13!3))	The channel that connects row 1 to column 13 in section 3 of the VX4380.
(@m6(65))	The channel that connects row 1 to column 1 in section 2 of the VX4380.
(@m6(1!1!2))	Same as the previous example.
(@m6(1:16))	The channels that connect columns 1 through 16 to row 1 in section 1 of the VX4380.
(@m6(1!1!1:1!16!1))	Same as the previous example.
(@m6(1!1!1:2!3!4))	Channels 1!1!1, 1!1!2, 1!1!3, 1!1!4, 1!2!1, 1!2!2, 1!2!3, 1!2!4, 1!3!1, 1!3!2, 1!3!3, 1!3!4, 2!1!1, 2!1!2, 2!1!3, 2!1!4, 2!2!1, 2!2!2, 2!2!3, 2!2!4, 2!3!1, 2!3!2, 2!3!3, 2!3!4 on the VX4380 Module.

As the <channel_list> syntax diagram shows, channels on more than one relay module may be specified in a <channel_list>. The next example specifies channels on three different relay modules.

<channel_list>	Channels Specified
(@m1(1!1), m2(4!6), m6(3!13!2))	Channel 1 of section 1 on the VX4320, Channel 4 of section 6 of the VX4330, and the channel on the VX4380 that connects row 3 to column 13 in section 2.

<list_of_lists> A list of <channel_lists> to be executed on one or more relay modules.

The syntax of a <list_of_lists> is supported on the VX4350 and VX4380 modules and is described by the following diagram:

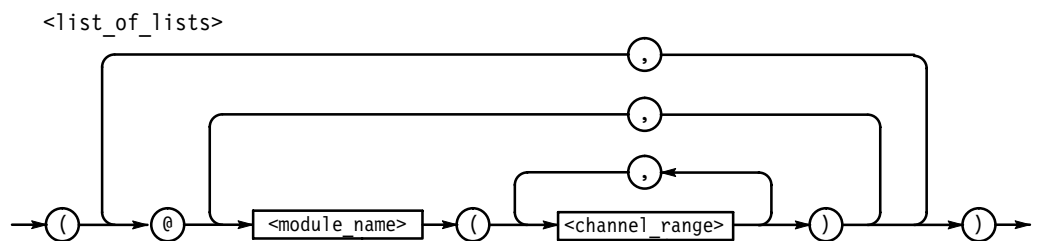

Each <channel_list> is identified by the @ character and represents a single location in the scan sequence. The syntax contains a list of channels that are operated simultaneously when the single location in the scan sequence is reached.

A maximum of eight channels may be specified in each <channel_range>.

As mentioned above, the module names used in <channel_list>s may be specified with a [ROUTE:]MODULE[:DEFINE] command. The command

```
route:module:Define rfmux, 1
```

changes the module name assigned to the VX4320 to “rfmux”. The following <channel_list> can then be used to specify channels on the VX4320.

```
(@rfmux(3!1,2!2))
```

specifies channel 3 in section 1 and channel 2 in section 2 of the VX4320.

The order in which channels are specified is important in the [ROUTE:] CLOSE? <channel_list> and [ROUTE:]OPEN? <channel_list> queries. The states of the channels are returned in the same order that the channels are specified in the <channel_list>.

The order in which channels are specified is also important in the [ROUTE:]SCAN <channel_list> command. This determines the order in which the relays will be closed each time a trigger event is detected.

The order in which channels are specified in a <channel_list> is important in the [ROUTE:]CLOSE <channel_list> command when channels in the same section of a VX4320 or a VX4330 are specified. A VX4320 can close only one channel in a section. If a [ROUTE:]CLOSE <channel_list> command specifies more than one relay in a section of a VX4320, the last channel in the <channel_list> will be closed.

For example, the command

```
close (@m2(1!1,2!1))
```

will close channel 2 of section 1 of the VX4320.

A VX4330 can close only one channel in a group of joined sections that have been specified in a [ROUTE:]CLOSE:MODE SCAN,<module_name>,<section_list> command. If more than one channel in such a group of sections is specified in a [ROUTE:]CLOSE <channel_list> command, the last channel specified will be closed. For example, the commands

```
route:configure:join m2,(1:6)
```

```
route:close:mode scan,m2,(1:6)
```

join the commons of all six sections of the VX4330 Module and set the mode of the [ROUTE:]CLOSE <channel_list> to scan mode for all six sections of the VX4330.

The command

```
route:close (@m2(1!1,1!6))
```

will then result in channel 1 of section 6 being closed and all other channels on the module being opened.

output queue The Output queue of the Option 01 VXI Interface is used to return replies to queries received by the interface. Bit 4 (the MAV bit) of the Status Byte register is set to indicate that this queue is not empty. The DOR bit in the VXI Response register is also set to indicate that this queue is not empty. The commander of the Option 01 VXI Interface monitors the DOR bit to determine when it may read a message from the Output queue.

<section_list>. One or more <nr1> fields separated by comma (,) or colon (:) characters and enclosed in left and right parentheses. A <section_list> is used to specify the sections of a relay module to be acted upon by a [ROUTE:]CONFig-

ure or [ROUTe:]CLOSe:MODE command. The following are examples of valid <section_list>s.

For commands directed to a VX4330 which has six scanner sections:

<section_list>	Sections Specified
(1:6)	Sections 1 through 6
(1,2,3)	Sections 1, 2 and 3
(1:3,5:6)	Sections 1 through 3 and 5 and 6
(1:3,5,6)	Same as previous example
(3)	Section 3

For commands directed to a VX4372 or VX4374 which has two scanner sections:

<section_list>	Sections Specified
(1)	Section 1
(1,2)	Sections 1 and 2
(1:2)	Sections 1 and 2

error/event queue. When the command parser detects a syntax error or data range error, it places an error message describing the error in the Error/Event queue. Bit 2 of the Status Byte Register is set to indicate that this queue is not empty. Bit 5 of the Standard Event Status Register (the Command Error bit) is set if the parser detects a syntax error. Bit 4 of the Standard Event Status register (the Execution Error bit) is set if the parser detects a numeric argument that is out of range. When a SYSTem:ERRor? query is received, an error message is dequeued from the Error/Event queue and placed in the Output queue.

Functional Command Groups

This section lists the VX4380 system and module commands.

System Commands

The following low-level commands are typically sent by the module's commander, and are transparent to the user of the module. (An exception is the Read STB command, which is sent whenever a Serial Poll on an IEEE-488 system is performed.) Most commanders or Slot 0 devices have specific ASCII commands that cause the commander to send one of these low-level commands to a specified instrument. Refer to the operating manual of the commander or Slot 0 device for information on these commands.

Command	Effect
Begin Normal Operation	The module begins operation if it has not already done so.
Byte Available	Transfers module commands to this module.
Byte Request	Requests the module to return a byte of data from the output queue.
Clear	The module clears its VXIbus interface and any pending commands. Current module operations are unaffected.
Clear Lock	Clears the Lock bit of the Response register.
Read Protocol	The module returns its protocol to its commander.
Read STB	The module returns its VXI status byte to its commander.
Set Lock	Set the Lock bit of the Response register.
Trigger	Close the next relay in a scan list that has been defined by a ROUTe:SCAN <channel_list> command. A VXI Trigger command is enabled as a trigger source by a ROUTe:SE-Quence:SOURce BUS command.

Module Commands

A summary of the VX4380-specific and IEEE-488.2 Common Commands is listed in Tables 3-1 and 3-2 below. The next section, *Command Descriptions*, includes detailed descriptions of each command. *Appendix C: Examples* shows examples of command usage.

Table 3–1: Summary of VX4380-Specific SCPI Commands

Subsystem Command	Functions Controlled
ABORt	Place initiated scan in the idle state
CLOSe	Close specified relays; DWELI
CONFigure	Configuration: DISJoin, JOIN
ID?	Return model numbers of modules controlled by the Option 01
INITiate	Place trigger subsystem in armed state: IMMEDIATE, CONTinuous
MODule	Module name functions: DEFine, CATalog?, DELete
OPEN	Open specified relays: ALL, DWELI
OUTPut	Enable or disable selected VXI TTL trigger
PFAil	Specify state of latching relays on powerfail
SCAN	Define a list of relay closures to scan through
STATus	Status register functions: OPERation, QUEStionable
SYSTem	System-level functions: ERRor?, PRESet, VERSion?
TRIGger	Scan list functions: COUNT, DELay, IMMEDIATE, SOURce

Table 3–2: Summary of IEEE-488.2 Common Commands

Command/Syntax	Description
Clear Status *CLS	Clears the SCPI and IEEE 488.2 event registers and the SCPI error/event queue, and the output queue.
Standard Event Status Enable *ESE <Nrf>	Sets the contents of the Standard Event Status Enable register.
Standard Event Status Enable Query *ESE?	Returns the current value of the Standard Event Status Enable register in <nr1> format.
Standard Event Status Register Query *ESR?	Returns the current value of the Standard Event Status register in <nr1> format, then set the contents of this register to 0.
Identification Query *IDN?	Returns an ASCII string in the output queue which identifies the board.
Operation Complete *OPC	Sets bit 0 (the Operation Complete bit) of the Standard Event Status register when all pending device operations have been completed.
Operation Complete Query *OPC?	Places the ASCII character 1 in the output queue when all pending device operations have been completed.
Reset* *RST	The Option 01 VXI interface is placed in its power-up state with some exceptions.

Table 3–2: Summary of IEEE-488.2 Common Commands (Cont.)

Command/Syntax	Description
Service Request Enable *SRE <NRf>	Sets the contents of the Service Request Enable register.
Service Request Enable Query *SRE?	Returns the current value of the Service Request Enable register in <nr1> format.
Read Status Byte Query *STB?	Returns the current value of the Status Byte register in <nr1> format.
Trigger *TRG	Equivalent to a VXI Trigger command.
Self-Test Query *TST?	Performs a self test of the Option 01 VXI Interface daughter board and any relay modules under its control. Place a "0" or "1" into the output queue to indicate whether the self test passed or failed.
Wait-to-Continue *WAI	Does not execute any further commands or queries until all pending operations have been completed.

Command Descriptions

This section lists the VX4380-specific SCPI commands and queries in alphabetic order. The IEEE-488.2 Common Commands are listed in the next section. A summary listing of the SCPI command set for the Option 01 is as follows:

ABORt

[ROUte:]CLOSe <channel_list>
[ROUte:]CLOSe:DWELl <module_name>,<nrf>

[ROUte:]ID?

INITiate:CONTInuous
INITiate[:IMMediate]

[ROUte:]MODule[:DEFine] <module_name>,<nrf>
[ROUte:]MODule:CATalog?
[ROUte:]MODule:DELeTe[:NAME] <module_name>
[ROUte:]MODule:DELeTe:ALL

[ROUte:]OPEN <channel_list>
[ROUte:]OPEN:ALL [module_name]
[ROUte:]OPEN:DWELl <module_name>,<nrf>

OUTPut:TTLTrg<n>[:STATe] ON | OFF | <nrf>

[ROUte:]PFAil <action_at_powerfail>

[ROUte:]SCAN <channel_list>

STATus:OPERation:CONDition?
STATus:OPERation:ENABle
STATus:OPERation[:EVENT?]
STATus:QUEStionable:CONDition?
STATus:QUEStionable:ENABle
STATus:QUEStionable[:EVENT?]

SYSTem:ERRor?
SYSTem:PRESet
SYSTem:VERSion?

TRIGger[:SEQuence]:COUNt
TRIGger[:SEQuence]:DELay
TRIGger[:SEQuence]:IMMediate
TRIGger[:SEQuence]:SOURce BUS | HOLD | IMMediate | TTLTrg<n>

ABORt

Command Syntax	ABORt
Query Syntax	N/A
*RST Value	N/A
Limits	N/A
Related Commands	ROUTE:SCAN, INITiate[:IMMediate], TRIGger[:SEQuence][:SOURce], TRIGger[:SEQuence][:IMMediate] TRIGger[:SEQuence][:COUNT] TRIGger[:SEQuence][:DELay]

Description This comand places an initiated scan sequence in the idle state.

Examples The following example defines a scan sequence of 10 relays. The sequence is aborted after the third relay in the sequence is closed. In this example, module names m1 and m2 refer to VX4380 Modules. After a scan sequence is aborted, triggers are no longer accepted by the Option 01 until another INITiate[:IMMediate] command is received.

Command	Response
route:scan (@m1(1:5),m2(60:64))	Define a scan sequence.
trigger:sequence: source hold	This command disables the following trigger sources: VXI TTL triggers, VXI Trigger commands, *TRG command, and IMMEDIATE triggers. The TRIGger[:SEQuence][:IMMediate] command, however, overrides this command. It triggers the module and skips the delay specified in a previously issued TRIGger[:SEQuence][:DELay] command.
initiate:immediate	Initiate the scan sequence.
trig	Close the first relay in the sequence.
trig	Open the first relay and close the second relay in the sequence.

Command	Response
trig	Open the second relay and close the third relay in the sequence.
abort	Abort the scan sequence.

CLOSe

Command Syntax [ROUte:]CLOSe<channel_list>

Query Syntax [ROUte:]CLOSe?<channel_list>

Query Response Indicates which relays are closed.

***RST Value** All relays on all modules are set to the open position.

Limits The syntax of a <channel_list> is described by the following diagram:

<channel_range>

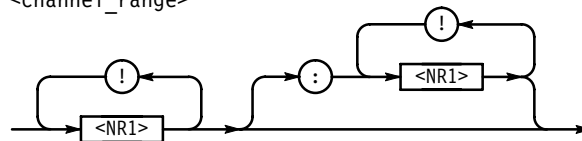

<channel_list>

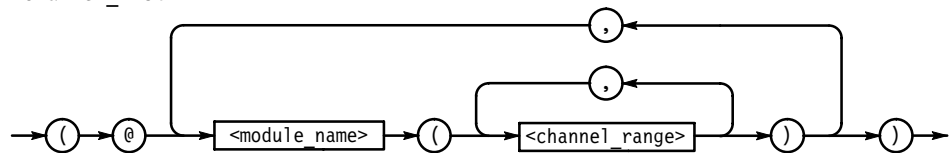

A `module_name` is an ASCII string that has been associated with a relay module in a [ROUte:]MODUle[:DEFine] command. A `channel_range` may consist of a single `<channel_spec>` or a range of `<channel_spec>`s. A range of `<channel_spec>`s consists of two `<channel_specs>` separated by a colon (:) character. One, two and three dimensional `<channel_spec>`s are supported for the VX4380.

A three dimensional `<channel_spec>` consists of three ASCII-encoded decimal integers separated by exclamation point characters (!). The first integer specifies a row, the second a column, and the third a section of the VX4380. For example, `<channel_spec> 2!3!4` specifies the relay that joins row 2 to column 3 in section 4 of the VX4380.

Two dimensional `<channel_spec>`s consist of two ASCII-encoded decimal integers separated by an exclamation point character. The first integer specifies a row and the second specifies a column. When a two dimensional `<channel_spec>` is issued, the section number defaults to 1. For example, `<channel_spec> 4!15` specifies the relay that joins row 4 to column 15 in section 1.

Related Commands [ROUte:]OPEN <channel_list>
 [ROUte:]MODUle:DEFine
 [ROUte:]CLOSE:DWELl
 OUTPut:TTLTrg<n>[:STATe]

A one dimensional <channel_spec> consists of a single ASCII-encoded decimal integer. The value of a one dimensional <channel_spec> can be determined from a three dimensional <channel_spec> by using the following formula:

$$((\text{section} - 1) \times 64) + ((\text{row} - 1) \times 16) + \text{column}$$

where variables “section”, “row”, and “column” are section, row and column numbers specified in a three dimensional <channel_spec>.

For example, the channel spec 3!10!2 specifies the relay that connects row 3 to column 10 in section 2. The equivalent one dimensional <channel_spec> is equal to $((2-1) \times 64) + ((3-1) \times 16) + 10 = 106$.

Description This command closes the relays specified in the <channel_list> portion of this command. After these relays are closed, a delay specified in a previously issued [ROUte:]CLOSE:DWELl command is generated. This command is used to assign a close delay to each module controlled by an Option 01 daughter board. If more than one module is specified in the <channel_list> argument of the [ROUte:]CLOSE command, the longest dwell time assigned to any of the specified modules is used. After this delay, VXI TTL triggers that have been enabled by a previously issued OUTPut:TTLTRG<n>:STATE command are pulsed low for 3 μsec.

Examples In this example, the Option 01 is installed on a VX4380 Module. Two additional VX4380 Modules are installed in consecutive slots to the right of the first VX4380. The default module names for these three modules are m1, m2, and m3. These module names may be altered with the [ROUte:]MODUle[:DEFine] command.

Command	Response
route:close:dwell m1,.1	Assign a close dwell time of 0.1 seconds to the first VX4380.
route:close:dwell m2,.2	Assign a close dwell time of 0.2 seconds to the second VX4380.
route:close:dwell m3,.5	Assign a close dwell time of 0.5 seconds to the third VX4380.
output:t1trg1:state on	Enable VXI TTL trigger 1.
output:t1trg4:state on	Enable VXI TTL trigger 4.

Command	Response
route:close (@m1(1:10))	Close the relays that connect row 1 to columns 1 through 10 in section 1 of the first VX4380, wait 0.1 seconds then pulse VXI TTL triggers 1 and 4 low for 3 μsec.
route:close (@m2(2!9!3,1!16))	Close the relay that connects row 2 to column 9 in section 3 and the relay that connects row 1 to column 16 of section 1 of the second VX4380. Wait 0.2 seconds, then pulse VXI TTL triggers 1 and 4 low for 3 μsec.
output:t1trg4:State off	Disable VXI TTL trigger 4.
close (@m1(1!1!2),m2(1!1!2), m3(1!1!2))	Close the relay that connects row 1 to column 1 in section 2 of each of the VX4380 Modules, wait 0.5 seconds, then pulse VXI TTL trigger 1 low for 3 μsec.

Command Syntax [ROUTE:]CLOSe
:DWELL<module_name>,<nrf>

Query Syntax N/A

***RST Value** The close dwell time of all modules is set to 0 seconds.

Limits The value of the time specified in this command must be between 0 and 6.5535 seconds.

Related Commands [ROUTE:]CLOSe
[ROUTE:]SCAN
OUTPut:TTLTrg<n>[:STATE]

Description Set the time to wait after closing a relay before proceeding and pulsing any enabled VXI TTL trigger signals.

Examples In this example the Option 01 is installed on a VX4380 Module.

Command	Response
output:t1trg1:state on	Enable VXI TTL trigger 1.
route:close:dwell m1,.25	Set the close dwell time for the VX4380 to 0.25 seconds.

Command	Response
route:open:dwel l m1,0.5	Set the open dwell time for the VX4380 to 0.5 seconds.
route:close (@m1(1!3:10!3))	Close relays 1 through 10 in section 3 of the VX4380, wait 0.25 seconds, then pulse VXI TTL trigger 1.
route:scan (@m1(1!6:20!6))	Define a scan list consisting of relays 1 through 20 in section 6 of the VX4380.
route:close (@m1(1!1!3:4!1!3))	Close the relays that connect rows 1 through 4 to column 1 in section 3 of the VX4380, wait 0.25 seconds, then pulse VXI TTL trigger 1.
scan (@m1(1!1!1:4!16!1,1!1! 2))	<p>Define a scan list consisting of all relays in section 1 and the relay that joins row 1 to column 1 in section 2. The relays in section 1 are specified in the following order:</p> <p>1!1!1, 1!2!1, 1!3!1, ..., 1!16!1,2!1!1, 2!2!1, 2!3!1, ..., 2!16!1,3!1!1, 3!2!1, 3!3!1, ..., 3!16!1,4!1!1, 4!2!1, 4!3!1, ..., 4!16!1</p> <p>Note that this scan list can be specified using one dimensional <channel_spec>s as: scan (@m1(1:65))</p>

After this sequence, each time the VXI TTL trigger 2 is pulsed low, the following sequence of events occurs:

1. One second delay. This is the delay specified in the trigger:Sequence:delay command.
2. The current relay in the scan list is opened.
3. 0.5 second delay. This is the delay specified in the route:open:dwell command.
4. Close the next relay in the scan list.
5. 0.25 second delay. This is the delay specified in the route:close:dwell command.
6. Pulse VXI TTL trigger 1 low for 3 μ sec.

ID?

Command Syntax	[ROUte:] ID?
*RST Value	N/A
Limits	N/A
Related Commands	[ROUte:]MODule:CATalog?

Description This query returns a list of the model numbers of the modules controlled by the Option 01. The first model number returned is that of the module that the Option 01 is installed on. Subsequent model numbers are those of modules in consecutive slots to the right of the first module.

Examples In these examples the Option 01 is installed on a VX4350 Module. A VX4380, VX4380, and VX4320 are installed in consecutive slots to the right of the slot containing the VX4350. The default module names for the VX4350, VX4380, VX4380 and VX4320 in this configuration are m1, m2, m3, and m4 respectively. These module names may be altered with the [ROUte:]MODule:DEFine command.

Command	Response
route: id?	VX4350, VX4380, VX4380, VX4320
route:module:Catalog?	"M1", "M2", "M3", "M4"
route:close (@m1(1))	Close relay number 1 on the VX4350.
route:open:all m2	Open all relays on the VX4380.
route:close (@m3(1!6))	Close relay number 1 in section 6 of the VX4380
route:close (@m4(3!1:3!8))	Close relay number 3 in all eight sections of the VX4320.

INITiate

Command Syntax	INITiate [:IMMEDIATE]
Query Syntax	N/A
Query Response	N/A
*RST Value	The trigger subsystem is in the idle state.

Related Commands	ABORt ROUte:SCAN TRIGger[:SEquence][:SOURce] TRIGger[:SEquence][:IMMEDIATE] TRIGger[:SEquence][:COUNt] TRIGger[:SEquence][:DELay]
-------------------------	--------------------------------------------------------------------------------------------------------------------------------------------------

Description	This command places the trigger subsystem in the armed state. In this state, a trigger event enabled by the TRIGger[:SEquence][:SOURce] command closes the next relay in a scan sequence, after opening the previous relay in the sequence. After a sufficient number of triggers have been received to cycle through a scan list the number of times specified in a TRIGger[:SEquence]:COUNt command, the trigger subsystem is placed in the idle state. In this state, triggers are ignored.
--------------------	------------------------------------------------------------------------------------------------------------------------------------------------------------------------------------------------------------------------------------------------------------------------------------------------------------------------------------------------------------------------------------------------------------------------------------------------------------------------------------------------

Examples	In this example, module names “m1” and “m2” have been assigned to VX4380 Modules.
-----------------	-----------------------------------------------------------------------------------

Command	Response
route:scan (@m1(1!1!1), m2(1!1!1,1!1!2))	Define a scan list consisting of 3 relays.
trigger:sequence: count 1	Define the number of times to sequence through the scan list before setting the state of the trigger subsystem back to the idle state.
initiate:immediate	Initiate the scan sequence.
trig	Close the first relay in the sequence.
trig	Open the first relay and close the second relay in the sequence.

Command	Response
trig	Open the second relay and close the third relay in the sequence.
trig	Open the third relay in the sequence. Place the trigger subsystem in the idle state.

Command Syntax INITiate
 :CONTInuous

Query Syntax N/A

***RST Value** The trigger subsystem is in the idle state.

Related Commands ABORt
 ROUte:SCAN
 TRIGger[:SEQuence][:SOURce]
 TRIGger[:SEQuence][:IMMEDIATE]
 [:SEQuence][:DELay]

Description If a scan list has been defined by a [ROUte:]SCAN command, this command places the trigger subsystem in the armed state. In this state, a trigger event enabled by the TRIGger[:SEQuence]:SOURce command opens the currently closed channel in a scan list and closes the next channel in the list. Triggers continue to be recognized until an ABORt command is received, which returns the trigger subsystem to the IDLE state.

Examples In this example, it is assumed that the Option 01 daughter board is installed on a VX4380 Module, and that the default module name “m1” is in effect.

Command	Response
scan (@m1(1:64))	Define a scan list consisting of all relays in section 1 of the VX4380 Module.
trigger:Sequence: count 2	Set the number of times to sequence through a scan list (when an INITiate[:IMMEDIATE] command is received) to 2.
trigger:sequence: source hold	Disable all trigger sources.
initiate:continuous	Place the trigger subsystem in the arm state.
trigger:seq:imm	Override the hold placed on triggers. Close channel 1 on the VX4380.

Command	Response
trigger:seq:imm	Override the hold placed on triggers. Open channel 1, then close channel 2 on the VX4380.
trigger:seq:sour imm	Remove the hold placed on triggers. Set the trigger source to immediate. This causes sequencing of the scan list indefinitely or until an ABORt command is received.
ABOR	Return the trigger subsystem to the idle state. Open the currently closed relay in the scan list.
initiate:immediate	Place the trigger subsystem in the arm state, sequence through the scan list twice, then return the trigger subsystem to the idle state.

MODule

Command Syntax	[ROUte:]MODule [:DEFine] <module_name>,<nrf>
Query Syntax	[ROUte:]MODule [:DEFine]? <module_name>
Query Response	See examples.
*RST Value	Default module names are assigned as follows: The module that has a Option 01 VXI Interface daughter board installed is assigned module name "M1". Modules without the Option 01 VXI Interface daughter board in consecutive slots to the right of module "M1" are assigned module names "M2", "M3", ..., "M11".
Limits	A module name may consist of up to 12 characters. The name must start with a letter and may consist of alphanumeric characters, underscores, and digits.
Related Commands	[ROUte]:MODule:DELEte[:NAME] [ROUte]:MODule:DELEte[:ALL] [ROUte:]MODule:CATalog?
Description	This command assigns a module name to a relay switching module. This name is used to identify the module in channel lists in [ROUte:]OPEN, [ROUte:]CLOSe, and [ROUte:]SCAN commands.
Examples	In these examples the Option 01 is installed on a VX4350 Module. A VX4380 and VX4380 are installed in consecutive slots to the right of the slot containing the VX4350.

Command	Response
route:module:define matrix,2	Assign module name "matrix" to the VX4380.
clos (@matrix(2!3!4))	Connect row 2 to column 3 in section 4 of the VX4380.

Command	Response
route:module:define? matrix	2
mod?matrix	2

Command Syntax [ROUte:]MODule
:CATalog?

***RST Value** N/A

Limits N/A

Related Commands [ROUte]:MODule:DEFine[:NAME]
[ROUte]:MODule:DELeTe[:NAME],
[ROUte]:MODule:DELeTe[:ALL]

Description This command returns a list of defined module names.

Examples In these examples the Option 01 is installed on a VX4350 Module. A VX4380 and VX4380 are installed in consecutive slots to the right of the slot containing the VX4350.

Command	Response
route:module:catalog?	"M1", "M2", "M3"
route:module:delete m1	Delete module name "M1"
route:module:catalog?	"M2", "M3"

Command Syntax [ROUte:]MODule
 :DElete
 [:NAME] <module_name>

Query Syntax N/A

***RST Value** N/A

Limits N/A

Related Commands [ROUte]:MODule:DEFine[:NAME]
 [ROUte]:MODule:CATalog?
 [ROUte:]MODule:DElete[:ALL]

Description This command deletes a module name definition. After this command is executed, the specified module name is no longer associated with a relay module.

Examples	Command	Response
	route:module:catalog?	"M1", "M2", "M3"
	route:module:delete m1	Delete module name "M1"
	route:module:catalog?	"M2", "M3"

Command Syntax [ROUte:]MODule
 :DElete
 :ALL

Query Syntax N/A

***RST Value** N/A

Limits N/A

Related Commands [ROUte]:MODUle:DEFine[:NAME]
[ROUte]:MODUle:CATalog?
[ROUte:]MODUle:DELEte[:NAME]

Description This command will delete all module name definitions.

Examples

Command	Response
route:module:catalog?	"M1", "M2", "M3"
route:module:delete: all	Delete all module names
route:module:catalog?	" "

OPEN

Command Syntax [ROUte:]OPEN <channel_list>

Query Syntax [ROUte:]OPEN? <channel_list>

Query Response See examples.

***RST Value** All relays on all modules are set to the open position.

Limits The syntax of a <channel_list> is described by the following diagram:

<channel_range>

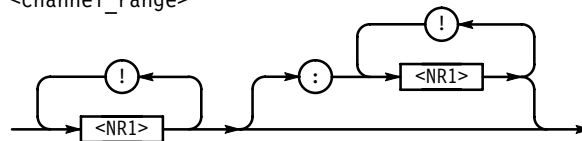

<channel_list>

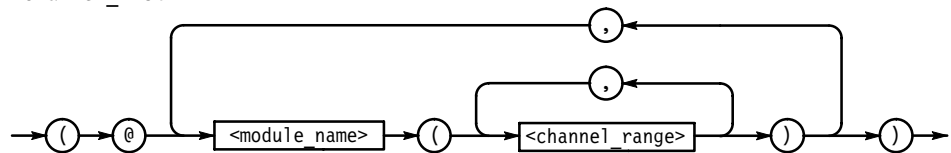

A `module_name` is an ASCII string that has been associated with a relay module in a [ROUte:]MODUle[:DEFine] command. A `channel_range` may consist of a single `<channel_spec>` or a range of `<channel_spec>`s. A range of `<channel_spec>`s consists of two `<channel_spec>`s separated by a colon (:) character. One, two and three dimensional `<channel_spec>`s are supported for the VX4380.

A three dimensional `<channel_spec>` consists of three ASCII-encoded decimal integers separated by exclamation point characters (!). The first integer specifies a row, the second a column, and the third a section of the VX4380. For example, `<channel_spec> 2!3!4` specifies the relay that joins row 2 to column 3 in section 4 of the VX4380.

Two dimensional `<channel_spec>`s consist of two ASCII-encoded decimal integers separated by an exclamation point character. The first integer specifies a row and the second specifies a column. When a two dimensional `<channel_spec>` is issued, the section number defaults to 1. For example, `<channel_spec> 4!15` specifies the relay that joins row 4 to column 15 in section 1.

A one dimensional <channel_spec> consists of a single ASCII-encoded decimal integer. The value of a one dimensional <channel_spec> can be determined from a three dimensional <channel_spec> by using the following formula:

$$((\text{section} - 1) \times 64) + ((\text{row} - 1) \times 16) + \text{column}$$

where variables “section”, “row”, and “column” are section, row and column numbers specified in a three dimensional <channel_spec>.

For example, the channel spec 3!10!2 specifies the relay that connects row 3 to column 10 in section 2. The equivalent one dimensional <channel_spec> is equal to $((2-1) \times 64) + ((3-1) \times 16) + 10 = 106$.

Related Commands [ROUTE:]CLOSe <channel_list>,
[ROUTE:]MODule:DEFine,
[ROUTE:]OPEN:DWELL

Description This command opens the relays specified in the <channel_list> portion of this command.

Examples In this example, the Option 01 is installed on a VX4380 Module. Two additional VX4380 Modules are installed in consecutive slots to the right of the first VX4380. The default module names for these three modules are m1, m2, and m3. These module names may be altered with the [ROUTE:]MODule[:DEFine] command.

Command	Response
route:open:dwell m1,.1	Assign a open dwell time of 0.1 seconds to the first VX4380.
route:open:dwell m2,.2	Assign a open dwell time of 0.2 seconds to the second VX4380.
route:open:dwell m3,.5	Assign a open dwell time of 0.5 seconds to the third VX4380.
route:open (@m1(1:10))	Open the relays that connect row 1 to columns 1 through 10 in section 1 of the first VX4380, then wait 0.1 seconds.
route:open (@m2(2!9!3,1!16))	Open the relay that connects row 2 to column 9 in section 3 and the relay that connects row 1 to column 16 of section 1 of the second VX4380, then wait 0.2 seconds.
open (@m1(1!1!2), m2(1!1!2), m3(1!1!2))	Open the relay that connects row 1 to column 1 in section 2 of each of the VX4380 modules, then wait 0.5 seconds.

Command	Response
open (@m1(1:64))	Open all relays in section 1 of the first VX4380, then wait 0.1 seconds.
open? (@m1(1:64))	<pre> 111111111111111111111111111111111111111111111111111111111111111111 111111111111111111111111111111111111111111111111111111111111111111 </pre> <p>This response indicates that all relays in section 1 of the first VX4380 are open.</p>

Command Syntax [ROUTe:]OPEN
:ALL [module_name]

Query Syntax N/A

***RST Value** All relays on all modules are set to the open position.

Limits N/A

Related Commands [ROUTe:]CLOSe,
[ROUTe:]MODUle:DEFine

Description If a module name is not specified in this command, open all relays on all modules controlled by the Option 01. If a module name is specified, open all relays on the specified module only. In either case do not change the state of the configuration relays on VX4380 Modules.

Examples

Command	Response
ROUTE:OPEN:ALL	Open all relays on all modules controlled by the Option 01. Do not change the state of the configuration relays on VX4380 Modules.
route:open:all	Same as the first example.
route:open:all gp	Open all relays on the module that has been assigned module name "gp". See the [ROUTe:]MODUle:DEFine command.

Command Syntax [ROUTe:]OPEN
:DWELl <module_name>,<nrf>

Query Syntax N/A

***RST Value** The open dwell time of all modules is set to 0 seconds.

Limits The value of the time specified in this command must be between 0 and 6.5535 seconds.

Related Commands [ROUTE:]OPEN,
[ROUTE:]SCAN

Description This command sets the time to wait after opening a relay before proceeding.

Examples In this example the Option 01 is installed on a VX4380 Module.

Command	Response
output:t1trg1:state on	Enable VXI TTL trigger 1.
route:close:dwell m1,.25	Set the close dwell time for the VX4380 to .25 seconds.
route:open:dwell m1,0.5	Set the open dwell time for the VX4380 to 0.5 seconds.
scan (@m1(1!1!1:4!16!1, 1!1!2))	Define a scan list consisting of all relays in section 1 and the relay that joins row 1 to column 1 in section 2. The relays in section 1 are specified in the following order: 1!1!1, 1!2!1, 1!3!1, ..., 1!16!1, 2!1!1, 2!2!1, 2!3!1, ..., 2!16!1, 3!1!1, 3!2!1, 3!3!1, ..., 3!16!1, 4!1!1, 4!2!1, 4!3!1, ..., 4!16!1 Note that this scan list can also be specified using one dimensional <channel_spec>s as :route:Scan (@m1(1:65))
trigger:Sequence: source:t1trg2	Define VXI TTL trigger 2 as the trigger source for the defined scan list.
trigger:sequence: delay 1	Set the trigger delay time to 1 second.
initiate:immediate	Initiate the scan sequence.

After this sequence, each time the VXI TTL trigger 2 is pulsed low, the following sequence of events occurs:

1. One second delay. This is the delay specified in the trigger:Sequence:delay command.
2. The current relay in the scan list is opened.

3. 0.5 second delay. This is the delay specified in the route:open:dwel command.
4. Close the next relay in the scan list.
5. 0.25 second delay. This is the delay specified in the route:close:dwel command.
6. Pulse VXI TTL trigger 1 low for 3 μ sec.

OUTPut

Command Syntax	<pre>OUTPut :TTLTrg<n> [:STATe] ON OFF <nrf></pre>
Query Syntax	<pre>OUTPut :TTLTrg<n> [:STATe]?</pre>
Query Response	Indicates whether a VXI TTL trigger is enabled.
*RST Value	All VXI TTL triggers are disabled.
Related Commands	<pre>ROUTe:CLOSe ROUTe:SCAN</pre>

Description One or more VXI TTL triggers may be enabled. Triggers that are enabled are pulsed low for 3 μ sec after a relay is closed by the Option 01 after a time specified by the ROUTe:CLOSe:DWELl command.

Examples

Command	Response
output:ttltrg1: state on	Enable driving VXI TTL trigger 1.
outp:ttl2 off	Disable driving VXI TTL trigger 2.
outp:ttl7:stat 1	Enable driving VXI TTL trigger 7.
output:ttltrg4:state?	1 This response indicates that VXI TTL trigger 4 is enabled.

PFAil

Command Syntax [ROUTE:]PFAil <action_at_powerfail>

Query Syntax N/A

***RST Value** All relays on all modules are opened when power is removed from the VXI chassis.

Limits N/A

Related Commands N/A

Description This command specifies the state that all latching relays on all modules controlled by the Option 01 are to be placed in when power is removed from the VXI chassis containing the modules. <action_at_powerfail> must be OPEN or SAME. If OPEN is specified, all latching relays are opened at powerfail. If SAME is specified, all latching relays are left in their current state at powerfail.

NOTE. VXI chassis +5 V power is maintained for 4 milliseconds after ACFAIL is asserted, in compliance with VXI Specifications. This allows for orderly system shutdown and implementation of the PFAil OPEN option.

Examples

Command	Response
route:pfail same	Leave all latching relays in their current state at powerfail.
route:pfail open	Open all latching relays at powerfail.

SCAN

Command Syntax [ROUTE:]SCAN <channel_list>
[ROUTE:]SCAN <list_of_lists>

Query Syntax N/A

***RST Value** No scan list is defined.

Limits The syntax of a <channel_list> is described by the following diagram:

<channel_range>

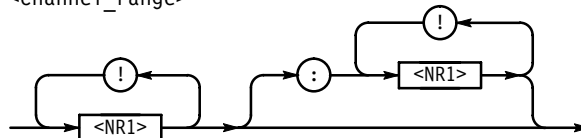

<channel_list>

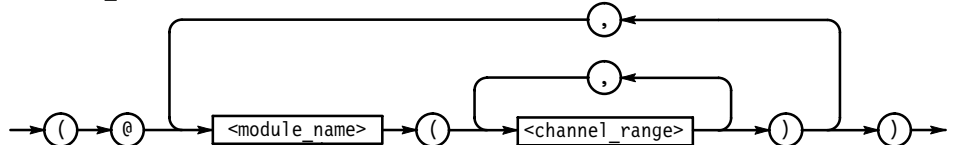

A module_name is an ASCII string that has been associated with a relay module in a [ROUTE:]MODULE[:DEFINE] command. A channel_range may consist of a single <channel_spec> or a range of <channel_spec>s. A range of <channel_spec>s consists of two <channel_specs> separated by a colon (:) character. One, two and three dimensional <channel_spec>s are supported for the VX4380.

A three dimensional <channel_spec> consists of three ASCII-encoded decimal integers separated by exclamation point characters (!). The first integer specifies a row, the second a column, and the third a section of the VX4380. For example, <channel_spec> 2!3!4 specifies the relay that joins row 2 to column 3 in section 4 of the VX4380.

Two dimensional <channel_spec>s consist of two ASCII-encoded decimal integers separated by an exclamation point character. The first integer specifies a row and the second specifies a column. When a two dimensional <channel_spec> is issued, the section number defaults to 1. For example, <channel_spec> 4!15 specifies the relay that joins row 4 to column 15 in section 1.

A one dimensional <channel_spec> consists of a single ASCII-encoded decimal integer. The value of a one dimensional <channel_spec> can be determined from a three dimensional <channel_spec> by using the following formula:

$$((\text{section} - 1) \times 64) + ((\text{row} - 1) \times 16) + \text{column}$$

where variables “section”, “row”, and “column” are section, row and column numbers specified in a three dimensional <channel_spec>.

For example, the channel spec 3!10!2 specifies the relay that connects row 3 to column 10 in section 2. The equivalent one dimensional <channel_spec> is equal to $((2-1) \times 64) + ((3-1) \times 16) + 10 = 106$.

The syntax of a <list_of_lists> is supported on the VX4350 and VX4380 modules and is described by the following diagram:

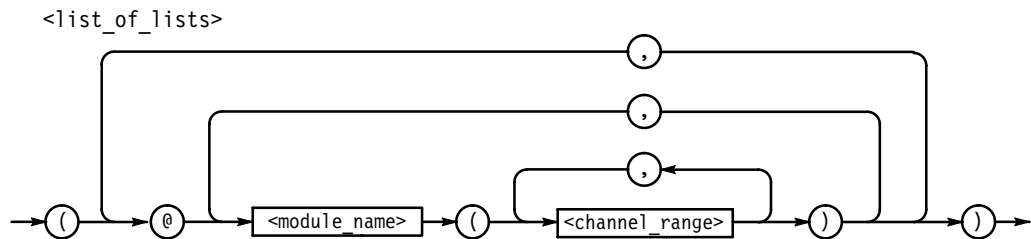

Each <channel_list> is identified by the @ character and represents a single location in the scan sequence. The syntax contains a list of channels that are operated simultaneously when the single location in the scan sequence is reached.

A maximum of eight channels may be specified in each <channel_range>.

Related Commands

ABORT
 TRIGger[:SEquence]:SOURce,
 TRIGger[:SEquence]:COUNt,
 TRIGger[:SEquence]:DELay,
 TRIGger[:SEquence]:IMMediate,
 TRIGger[:SEquence]:COUNt,
 INITiate:CONTinuous
 INITiate[:IMMediate],
 [ROUte:]CLOSe:DWELl
 [ROUte:]OPEN:DWELl

Description

This command defines a list of relay closures to sequence through. This list is called a scan list. When the ROUTe:SCAN <channel_list> command is received, all relays in this list are opened. In addition to defining a scan list, a trigger source must be specified using the TRIGger[:SEquence]:SOURce command.

Trigger events are not recognized until triggers are armed by a `INITiate[:IM-Mediate]` or `INITiate:CONTinuous` command.

When the first trigger event is detected, the first relay in the scan list is closed. When the second trigger event is detected, the first relay is opened and the second relay is closed. When the *n*th trigger event is detected, the (*n*-1)th relay is opened and the *n*th relay is closed. The act of opening the (*n*-1)th relay and closing the *n*th relay is called sequencing the scan list. At any given time after the first trigger event is detected, only one relay in the scan list is closed.

The `TRIGger[:SEquence]:COUNT` command may optionally be used to specify the number of times to sequence through the entire scan list. The `TRIGger[:SE-Quence]:DELay`, `[ROUTE:]CLOSE:DWELL`, and `[ROUTE:]OPEN:DWELL` commands may optionally be used to specify the time to wait after a trigger event is detected, a relay is closed or a relay is opened. A `TRIGger[:SE-Quence]:IMMediate` command causes the scan list to be sequenced without the delay specified by a previously issued `TRIGger[:SEquence]:DELay` command.

Examples

In these examples the Option 01 is installed on a VX4350 Module. A VX4380 and VX4380 are installed in consecutive slots to the right of the slot containing the VX4350.

Command	Response
<code>route:module:define gp,1</code>	Assign module name "gp" to the VX4350.
<code>route:module:define matrix,2</code>	Assign module name "matrix" to the VX4380.
<code>route:module:define scan,3</code>	Assign module name "scan" to the VX4380.
<code>route:scan (@gp(1:64), matrix(1!1!1,2!10!3), scan(1!1:20!1))</code>	Define a scan list consisting of relays 1 through 64 on the VX4350, relays at row 1, column 1 of section 1 and row 2, column 10 of section 3 of the VX4380 and relays 1 through 20 of section 1 of the VX4380.
<code>trigger:sequence:source immediate</code>	Define a trigger source of "immediate". This means to sequence through the scan list without waiting for a trigger event.
<code>trigger:sequence:count 5</code>	Sequence through the entire scan list 5 times.
<code>route:close:dwll gp,.5</code>	Wait 0.5 seconds after closing a relay on the VX4350.
<code>initiate:immediate</code>	Begin sequencing through the scan list.
<code>*OPC</code>	Set the Operation Complete bit of the Standard Event Status register after sequencing through the scan list five times.

Command	Response
route:scan (@gp(1:8), @gp(9:16), @gp(17:24))	Define a scan list of three entries on the VX4350, each entry consisting of eight relays to be closed simultaneously.
initiate:immediate	Begin sequencing through the scan list.
*OPC	Set the Operation Complete bit of the Standard Event Status register after sequencing through the scan list five times.
route:scan (@gp(1), matrix(1!1!1), scan(1!3!3), @gp(2), matrix(1!2!2), scan(1!2!2), @gp(3), matrix(1!3!3), scan(1!1!1))	Define a scan list of three entries. Each entry consists of a single relay on the VX4350 and a single relay on each of the VX4380s to be closed simultaneously.
initiate:immediate	
*OPC	

STATus

Command Syntax STATus
 :OPERation
 :CONDition?

***RST Value** 0

Limits N/A

Related Commands N/A

Description This query returns the contents of the SCPI Status Operation Condition register. For the Option 01, the value of this register is always equal to 0.

Examples

Command	Response
status:operation:condition?	00000

Command Syntax STATus
 :OPERation
 :ENABle

Query Syntax STATus:
 OPERation
 :ENABle?

***RST Value** 0

Limits N/A

Related Commands N/A

Description This command sets the contents of the SCPI Status Operation Event Enable register.

Examples	Command	Response
	status:operation:enable 1	No response
	stat:oper:enab?	00001

Command Syntax STATus
 :OPERation
 [:EVENT?]

***RST Value** 0

Limits N/A

Related Commands N/A

Description This query returns the contents of the SCPI Status Operation Event register. For the Option 01, the value of this register is always equal to 0.

Examples	Command	Response
	status:operation:event?	00000

Command Syntax STATus
 :QUESTionable
 :CONDition?

***RST Value** 0

Limits N/A

Related Commands N/A

Description This query returns the contents of the SCPI Status Questionable Condition register. For the Option 01, the value of this register is always equal to 0.

Examples

Command	Response
status:questionable:condition?	00000

Command Syntax

STATus
 :QUEStionable
 :ENABle

Query Syntax

STATus
 :QUEStionable
 :ENABle?

Query Response

Indicates whether the Status Operation Event is enabled.

***RST Value**

0

Limits

N/A

Related Commands

N/A

Description

This command sets the contents of the SCPI Status Operation Event Enable register.

Examples

Command	Response
status:questionable:enable 1	No response
stat:ques:enab?	00001

Command Syntax STATus
 :QUEStionable
 [:EVENT?]

***RST Value** 0

Limits N/A

Related Commands N/A

Description This query returns the contents of the SCPI Status Questionable Event register. For the Option 01, the value of this register is always equal to 0.

Examples

Command	Response
status:questionable: event?	00000

SYSTem

Command Syntax	<p>SYSTem</p> <p>:ERRor?</p>
Query Response	<p>Parameter “y” in these error messages represents the local bus address of the module that the error message applies to. A value of 1 indicates the module containing the Option 01 daughter board, a value of 2 indicates the module in the next slot to the right, and so on.</p> <p>0, “No error”</p> <p>–102, “Syntax error; 1 dimensional <channel_spec> invalid for VX4380 module”</p> <p>–102, “Syntax error; 2 dimensional <channel_spec> invalid for VX4350 module”</p> <p>–102, “Syntax error; 3 dimensional <channel_spec> invalid for VX43xx module”</p> <p>–102, “Syntax error; channel dimension mismatch”</p> <p>–102, “Syntax error; integer field greater than 10 characters”</p> <p>–102, “Syntax error; Missing module name”</p> <p>–102, “Syntax error; Module address not specified”</p> <p>–102, “Syntax error; Module name already defined”</p> <p>–102, “Syntax error; Module name length greater than 12 characters”</p> <p>–102, “Syntax error; Non-contiguous section numbers”</p> <p>–102, “Syntax error; ROUTe:CONFigure command invalid for VX43xx module”</p> <p>–102, “Syntax error; ROUTe:DISJoin command invalid for VX43xx module”</p> <p>–102, “Syntax error; ROUTe:JOIN command invalid for VX43xx module”</p> <p>–102, “Syntax error; ROUTe:MODE command invalid for VX43xx module”</p> <p>–102, “Syntax error; Undefined module name”</p> <p>–102, “Syntax error; Unexpected x detected while ...”</p> <p>–121, “Invalid character in number”</p> <p>–123, “Exponent too large”</p>

- 200, "Execution error; Reserved"
- 200, "Execution error; Scan list undefined"
- 211, "Trigger ignored"
- 213, "Init ignored"
- 222, "Data out of range; Channel number x on module y"
- 222, "Data out of range; Channel number x!x on module y"
- 222, "Data out of range; Channel number x!x!x on module y"
- 222, "Data out of range; Invalid module address specified"
- 222, "Data out of range; Invalid section number"
- 222, "Data out of range; Invalid sequence count"
- 222, "Data out of range; Invalid trigger delay"
- 222, "Data out of range; Invalid VXI TTL Trigger level"
- 222, "Data out of range; Maximum value for ESE command is 255"
- 222, "Data out of range; Maximum value for SRE command is 255"
- 222, "Data out of range; Invalid dwell time specified."
- 223, "Too much data; Channel list array overflow"
- 223, "Too much data; Input buffer overflow"
- 223, "Too much data; Output buffer full"
- 223, "Too much data; Scan list array overflow"
- 240, "Hardware error; Shift register verification error – module y"
- 240, "Hardware error; Unrecognized module x, y"
- 350, "Queue overflow; Error/event queue"
- 350, "Queue overflow; Output queue"

*RST Value	The Error/Event queue is empty.
Limits	N/A
Related Commands	*ESR?, *STB?

Description If an error condition is detected by the Option 01, it places an error message describing the condition in the error/event queue. The SYSTem:ERRor? query requests the Option 01 to remove the oldest message in the error/event queue and place it into the output queue. If the error/event queue is empty, a “No error” message is placed in the output queue.

Examples	Command	Response
	SYSTem:ERROR?	0, “No error”
	syst:err?	-222, “Data out of range; Invalid section number”

Command Syntax SYSTem:
PRESet

Query Syntax N/A

***RST Value** N/A

Limits N/A

Related Commands ROUTe:OPEN:ALL

Description All relays on all modules (except VX4320 Modules) are set to the open position. The PON bit of the Standard Event Status register is not affected by this command.

Examples	Command	Response
	system:preset	No response
	syst:pres	No response

Command Syntax SYSTem
:VERSion?

***RST Value** N/A

Limits N/A

Related Commands None

Description This query returns the following ASCII string in the output queue:
"1994.0"

Examples

Command	Response
system:version?	"1994.0"
syst:vers?	"1994.0"

TRIGger

Command Syntax TRIGger
 [:SEquence]
 :COUNT

Query Syntax N/A

***RST Value** 1

Limits The count specified in this command must be between 1 and 65535.

Related Commands ABORt, ROUTe:SCAN
 INITiate:IMMediate
 TRIGger[:SEquence]:SOURce]
 TRIGger[:SEquence]:IMMediate]
 TRIGger[:SEquence]:DELay]

Description This command specifies the number of times to sequence through an entire scan sequence.

Examples Define a scan sequence consisting of relays 1 and 2 on relay module “m1” and relays 1 through 64 on module “m2”.

Command	Response
trigger:sequence:count 2	Define the number of times to sequence through the scan list before setting the state of the trigger subsystem back to the idle state.
trigger:sequence: source immediate	Sequence through the scan list without waiting for a trigger event after an INITiate[:Immediate] command is received.
initiate:immediate	Initiate the scan sequence. Sequence through the entire scan list two times.

Command Syntax TRIGger
 [:SEquence]
 :DELay

Query Syntax N/A

***RST Value** 0

Limits The time specified in this command must be between 0.001 and 6.5535 seconds.

Related Commands ABORt, ROUTe:SCAN
 TRIGger[:SEQuence]:SOURce
 TRIGger[:SEQuence]:IMMediate

Description This command specifies the time to wait after a trigger event is detected before sequencing to the next channel in a scan list.

Examples

Command	Response
route:scan (@m1(1,2),m2(1:64))	Define a scan sequence consisting of relays 1 and 2 on relay module "m1" and relays 1 through 64 on module "m2".
trigger:sequence: count 2	Define the number of times to sequence through the scan list before setting the state of the trigger subsystem back to the idle state.
trigger:sequence: delay 0.5	Wait 0.5 seconds after a trigger event is detected before opening the current relay in a scan list and closing the next relay in the list.
trigger:sequence: source ttltrg2	Sequence to the next relay in a scan list when VXI TTL trigger 2 is asserted.
initiate:immediate	Initiate the scan sequence. Sequence through the entire scan list two times. Wait 0.5 seconds after VXI TTL trigger 2 is asserted before sequencing to the next relay in the list.

Command Syntax TRIGger
 [:SEQuence]
 :IMMediate

Query Syntax N/A

***RST Value** N/A

Limits N/A

Related Commands ABORt, ROUTe:SCAN
 TRIGger[:SEQuence]:SOURce
 TRIGger[:SEQuence]:COUNT
 TRIGger[:SEQuence]:DELay

Description Sequence to the next relay in an initiated scan list without waiting for a trigger event and without waiting the time specified in a TRIGger[:SEQuence]:DELay command.

Examples

Command	Response
route:scan (@m1(1,2),m2(1:64))	Define a scan sequence consisting of relays 1 and 2 on relay module "m1" and relays 1 through 64 on module "m2".
trigger:sequence: count 2	Define the number of times to sequence through the scan list before setting the state of the trigger subsystem back to the idle state.
trigger:sequence: delay 0.5	Wait 0.5 seconds after a trigger event is detected before opening the current relay in a scan list and closing the next relay in the list.
trigger:sequence: source ttltrg2	Sequence to the next relay in a scan list when VXI TTL trigger 2 is asserted.
initiate:immediate	Initiate the scan sequence. Sequence through the entire scan list 2 times. Wait 0.5 seconds after VXI TTL trigger 2 is asserted before sequencing to the next relay in the list.
trigger:sequence: immediate	Sequence to the next relay in the scan list without waiting for VXI TTL trigger 2 to be asserted. Do not wait 0.5 seconds to sequence to the next relay.

Command Syntax TRIGger
 [:SEQuence]
 :SOURce BUS | HOLD | IMMEDIATE | TTLTrg<n>

Query Syntax N/A

***RST Value** IMMEDIATE

Limits N/A

Related Commands ABORt, ROUTe:SCAN
 TRIGger[:SEQuence]:[SOURce]
 TRIGger[:SEQuence]:[IMMEDIATE]

TRIGger[:SEquence]:COUNT
 TRIGger[:SEquence]:DELAY

Description This command selects a trigger source. When a trigger event is detected from an enabled trigger source, the next relay in an initiated scan sequence is closed after the current closed relay is opened.

The action of opening the currently closed relay and closing the next relay in a scan list is called sequencing the scan list.

Specifying BUS in the TRIGger[:SEquence]:SOURce command enables a IEEE488.1 Group Execute Trigger command to sequence the scan list.

It is assumed that the commander of the Option 01 is a IEEE488 talker/listener and that this device converts a IEEE488.1 GET command to a VXI Trigger command.

Specifying HOLD in the TRIGger[:SEquence]:SOURce command disables all trigger sources except the TRIGger[:SEquence][:IMMediate] comand.

Specifying IMMEDIATE in the TRIGger[:SEquence]:SOURce command causes the Option 01 to sequence through the scan list without waiting for a trigger event.

Specifying TTLTrg<n> in the TRIGger[:SEquence]:SOURce command enables one of eight VXI TTL triggers to act as a trigger source. <n> is a single digit between 0 and 7.

Examples

Command	Response
route:scan (@m1(1,2),m2(1:64))	Define a scan sequence consisting of relays 1 and 2 on relay module "m1" and relays 1 through 64 on module "m2".
trigger:sequence: count 2	Define the number of times to sequence through the scan list before setting the state of the trigger subsystem back to the idle state.
trigger:sequence: source:immediate	Sequence through the scan list without waiting for a trigger event after an INITiate[:ImMediate] command is received.
initiate:immediate	Initiate the scan sequence. Sequence through the entire scan list two times.

IEEE-488.2 Common Commands

This section lists the IEEE-488.2 common commands and queries recognized by the VX4380.

*CLS

Clear Status. This commands clears the following:

- Event Status register (ESR)
- Error/Event queue
- Output queue

*ESE <NRf>

Event Status Enable (ESE) command. This command defines the mask for setting the Event Status Summary bit (bit 5) in the Status Byte register (*STB?). The mask is logically ANDed with the Event Status register (*ESR?) to determine whether or not to set the Event Status Summary bit. The mask can be any numeric value from 0 to 255, corresponding to the encoded bits of the ESR register. A “1” in a bit position enables reporting of the function. A “0” disables it. The *ESE register is cleared at power-on, or by writing an *ESE 0 command only. If <mask> is not specified, it defaults to 0.

For example, the command *ESE 37 (hexadecimal 25, binary 00010101) enables setting the Event Status Summary bit whenever an operation is complete, a query error is detected, or an execution error is detected.

*ESE?

Event Status Enable (ESE) query. This command returns the value of the Event Status Enable register as a numeric value from 0 to 255. For example, a value of 32 (hexadecimal 40, binary 00100000) indicates that command error reporting is enabled.

*ESR?

Event Status Register (ESR) query. This command returns the value of the Event Status register. The *ESR command is destructively read (that is, read and cleared). The Event Status Summary bit in the Status Byte (*STB?) is also cleared by a read of the ESR. The ESR is set to 128 on power-on (bit 7) set. It is

cleared by an *ESR? or *CLS command only. When converted to a binary number, the bits of the ESR correspond to:

bit 0 (LSB)	Operation Complete
1	Request Control
2	Query error
3	Device Dependent error
4	Execution error
5	Command error
6	User Request
7 (MSB)	Power On

The Error bits are set whenever the module detects an error. The error values from -100 to -199 are Command errors. Error values from -200 to -299 are Execution errors. Error values from -300 to -399 are Device Dependent errors. Error values from -400 to -499 are Query errors (see the SYSTEM:ERRor command description).

The Request Control and User Request bits are unused, and are always reported as zeroes.

The Operation Complete bit is set in response to an *OPC command. A 1 indicates that the module has completed all pending commands and queries.

*IDN?

Identification query; This returns a 4-field response. Field 1 is the manufacturer, field 2 the model, field 3 the serial number, and field 4 contains both the SCPI and the firmware version levels. For the VX4380, the serial number field is always a 0. The response syntax is:

```
TEKTRONIX,VX43xx,0,SCPI:94.0 FW1.1<LF>
```

where xx indicates the model number of the relay module that the Option 01 is installed on:

Value of xx	Model Number
20	VX4320
30	VX4330
50	VX4350
80	VX4380

***OPC**

Operation Complete. This command causes the module to set the Operation Complete bit in the Event Status register (ESR) when all pending commands and queries are complete.

***OPC?**

Operation Complete query. This command causes the module to place a “1” in the Output queue when all pending commands and queries are complete. All commands following *OPC are suspended until the pending operations are complete. The *OPC? command does not affect the OPC bit in the Event Status register.

***RST**

Reset. This command causes the Option 01 to open all relays on all modules under its control. This command sets the Option 01 Module to its power-on state with the following exceptions: the Error/Event queue, Output queue, Standard Event Status Enable register, SCPI Status Operation Event Enable register and SCPI Status Questionable Event Enable register are not cleared.

The condition of the Option 01 daughter board and the switching modules that it controls after receipt of a *RST command is as follows:

- Contents of the SCPI Status Operation Event register = 0
- Contents of the SCPI Status Operation Condition register = 0
- Contents of the SCPI Status Questionable Event register = 0
- Contents of the SCPI Status Questionable Condition register = 0
- All VXI TTL triggers are disabled
- Trigger subsystem is in the idle state
- Trigger source = IMMEDIATE
- Number of times to sequence through an entire scan list = 1
- Time in seconds to wait after a trigger event is detected before sequencing to the Next relay in a scan list = 0
- All relays on all modules are set to the open position
- No scan list is defined

Default module names are assigned as follows:

The module that has a Option 01 VXI Interface daughter board installed is assigned module name “M1”.

Modules without the Option 01 VXI Interface daughter board in consecutive slots to the right of module “M1” are assigned module names “M2”, “M3”, ..., “M11”.

All sections on all scanner modules are disjoined
All sections of all VX4330 Modules are set to operate in the mux mode
Close dwell time of all modules is set to 0 seconds
Open dwell time of all modules is set to 0 seconds
All relays on all modules are opened when power is removed from the VXI chassis

*SRE <mask>

Service Request Enable (SRE) register. This command defines a mask that is ANDed with the contents of the Status Byte register. If the result of this operation is non-zero, the Option 01 generates a VXI Request True interrupt. Bits 0, 1, 3, 6, and 7 of the SRE register are not used. Bits 2, 4, and 5 are set to enable VXI Request True interrupts to be generated under the conditions listed in the following table.

Bit No.	Meaning
bit0 (LSB)	Not used
1	Not used
2	The Error/Event queue contains one or more error messages
3	Not used
4	The Output queue contains one or more query responses
5	The contents of the Standard Event Status register ANDed with the contents of the Standard Event Status Enable register produces a non-zero result.
6	Not used
7	Not used

*SRE?

Service Request Enable (SRE) query. This command returns the value of the Service Request Enable register as a numeric value from 0 to 255. Bit 6 is unused, and is reported as zero.

***STB?**

Status Byte Query. This query returns the value of the Status Byte register as a numeric value between 0 and 255. The Status Byte register contents (with the exception of bit 6) are also returned in response to a VXI Read STB command. Bit 6 is read destructively in response to a VXI Read STB command. Bit 6 is not read destructively in response to a *STB? query. The Status Byte register is encoded as follows:

Bit No.	Meaning
bit 0 (lsb)	Not used
bit 1	Not used
bit 2	Set when the Error/Event queue contains one or more error messages.
bit 3	Not used
bit 4	Set when the Output buffer contains one or more query responses.
bit 5	Set when the contents of the Standard Event Status register ANDed with the contents of the Standard Event Status Enable register produces a non-zero result.
bit 6	<p>Set when the contents of bits 0 through 5 and bit 7 of the Status Byte register ANDed with the contents of the Service Request Enable register produce a non-zero result.</p> <p>If bit 6 becomes set, the Option 01 will generate a VXI Request True interrupt on the VME interrupt level selected by its interrupt level select switch. If bit 6 becomes set and the Status Byte register is read using a VXI Read STB command, bit 6 will be reported as being set. In response to subsequent VXI Read STB commands, bit 6 will be reported as being cleared.</p> <p>If bit 6 becomes set and the Status Byte register is read using a *STB? query, bit 6 will be reported as being set. Bit 6 will continue to be reported as set in response to *STB queries until the contents of bits 0 through 5 and bit 7 of the Status Byte register ANDed with the contents of the Service Request Enable register is equal to 0.</p>
bit 7	Not used.

***TRG**

Trigger Command. This command is equivalent to a VXI Trigger command. This command is valid only after the following commands have been received by the Option 01:

Command	Description
[ROUte:]SCAN <channel_list>	Define a scan list
TRIGger [:SEQuence] :SOURce BUS	Select a VXI Trigger command as a trigger source.
INITiate[:IMMediate]	Initiate the scan list. This command places the trigger subsystem in the "ARM" state. The trigger subsystem remains in this state until the Option 01 has sequenced through the entire scan list "n" times, where "n" has been previously specified in a TRIGger[:SEQuence]:COUNT command. The trigger subsystem then returns to the IDLE state. The trigger subsystem also returns to the IDLE state if an ABORT command is received by the Option 01.

After these commands have been issued, a *TRG command will cause the Option 01 to take the following actions:

Generate a trigger delay that has previously been specified in a TRIGger[:SEQuence]:DELay command.

Open the currently closed channel.

Generate the open delay that has previously been specified in a [ROUte:]OPEN:DWELl command.

Close the next channel in the scan list.

Generate the close delay that has previously been specified in a [ROUte:]CLOSe:DWELl.

Pulse one or more VXI TTL trigger signals that have been enabled by a previously issued OUTPut:TTLTRG<n>[:STATe] ON command.

If the module containing the channel is a scanner module, pulse the appropriate front panel encode signal.

If another *TRG command is received before this sequence is complete, a SCPI -211, "Trigger ignored" error message will be placed in the Error/Event queue. The *TRG command will continue to have this effect until the trigger subsystem is placed in the IDLE state. If additional *TRG commands are received after the

trigger system is placed in the IDLE state, the Option 01 will place a SCPI -211, "Trigger Ignored" error message in the Error/Event queue.

The IEEE-488.2 Specification equates the *TRG command with an IEEE-488.1 Group Execute Trigger (GET) command. IEEE-488-to-VXI interface modules typically convert IEEE-488.1 GET commands to VXI Trigger commands. For this reason, the Option 01 equates the *TRG command with a VXI Trigger command.

***TST?**

Self Test query. In response to this query, the Option 01 performs a self test of each of the switching modules under its control. During self test, the Option 01 verifies that it can properly control the relay drive circuitry of each switching module under its control. After the self test is complete, each module is restored to its pretest state. If all modules pass self test, an ASCII "0" is placed in the Output buffer. If one or more modules fail the self test, an ASCII "1" is placed in the Output buffer and error message(s) describing the failure are queued in the Error/Event queue. Issue a SYSTem:ERRor? query to read these error messages.

***WAI**

Wait to Continue. This command causes the module to wait until all pending commands and queries are complete. All commands following *WAI are suspended until the pending operations are complete.



Status and Events

Status and Events

The Status and Event Reporting System reports asynchronous events and errors that occur in the VX4380 256-Crosspoint Relay Matrix Module. This system consists of four 8-bit registers and two queues that you access through the command language. You can use these registers and queues to query the instrument status and control the interrupts that report events.

In general, after an interrupt occurs, first conduct a serial poll, query the registers to see why the interrupt occurred, and then send the SYSTem:ERRor? query to see a descriptive error message.

This section describes the four registers and two queues of the Status and Event Reporting system. For each register, you are given a description, a table describing all of the bits, and an example of how to use the register.

The Status and Event Reporting process, synchronizing programming commands, and the system messages are also described in this section.

Status and Event Reporting System

The Status and Event Reporting system monitors and reports such events as an error occurring or the availability of a response to a query. This system includes descriptions of the following registers and queues:

- Status Byte Register
- Service Request Enable Register
- Standard Event Status Register
- Event Status Enable Register
- Output queue
- System Error and Event queue

Status Byte Register

The Status Byte Register, shown in Table 4–1, summarizes information from other registers. Use a serial poll or a *STB? query to read the contents of the Status Byte Register. The response is the sum of the decimal values for all bits set. When you use a serial poll, bit 6 shows Request Service information. When you use the *STB? query, bit 6, the Master Status Summary bit, indicates that bits 5, 4, or 2 may be set.

Table 4-1: The Status Byte Register

Bit	Decimal Value	Function
0-1	-	Not used.
2	4	Error/Event queue Not Empty indicates that information is contained in the Error/Event queue and is waiting to be read.
3	-	Not used.
4	16	Message Available shows that output is available in the Output queue.
5	32	Event Status Bit indicates that one or more events have occurred and the corresponding bits in the Standard Event Status Register have been set.
6	64	Request Service (obtained from a serial poll) shows that the VX4380 has requested service from the GPIB controller. Master Status Summary (obtained from *STB? query) summarizes the Event Status bit, Message Available bits, and Error/Event queue Not Empty bits in the Status Byte Register.
7	-	Not used.

A common example of using the Status Byte register is to enable the Message Available bit. This is done by sending an *SRE 16 command to the Option 01 VXI Interface Module. If the *STB? query returns a value of 80, bit 4 (decimal value of 16) and bit 6 (decimal value of 64) have been set (giving a decimal sum of 80). Bit 4 indicates that a message is available in the output queue. Bit 6 indicates that a bit in the Status Byte register that has been enabled by setting the corresponding bit in the Service Request Enable register (in this case bit 4) has been set.

Service Request Enable Register

The Service Request Enable Register, shown in Table 4-2, controls which bits in the Status Byte Register will generate a service request. Use the *SRE command to set bits in the Service Request Enable Register. Use the *SRE? query to see which bits in this register are enabled. The response from this query is the sum of the decimal values for all bits set.

Table 4-2: The Service Request Enable Register

Bit	Decimal Value	Function
0-1	-	Not used
2	4	Error/Event queue Bit indicates that a service request will be generated when a message is placed in the Error/Event queue.

Table 4-2: The Service Request Enable Register (Cont.)

Bit	Decimal Value	Function
3	8	Not used
4	16	Message Available Bit indicates that a service request will be generated when a message is placed in the Output queue.
5	32	Event Status Bit indicates that events summarized in bit 5 of the Status Byte Register will generate a service request.
6-7	-	Not used

If, for example, the *SRE? query returns a value of 48, bits 4 and 5 are set in the Service Request Enable Register. Any event that causes the Message Available bit (bit 4) or Event Status bit (bit 5) to be set in the Status Byte Register now generates an interrupt. If you want an interrupt to be generated only when the Event Status bit (bit 5) is set, use the *SRE 32 command.

Standard Event Status Register

The Standard Event Status Register, shown in Table 4-3, records many types of events that can occur in the VX4380. Use the *ESR? query to read the contents of this register. The response is the sum of the decimal values for all bits set. Reading this register clears all bits so the register can accumulate information about new events.

Table 4-3: The Standard Event Status Register

Bit	Decimal Value	Function
0	1	Operation Complete shows that the operation is complete. This bit is set when all pending operations complete following a *OPC command.
1	-	Not used
2	4	Query Error shows that data in the Output queue was lost.
3	8	Not used
4	16	Execution Error shows that an error occurred while the VX4380 was executing a command or query. Table 4-6 on page 4-7 lists the execution error messages.
5	32	Command Error shows that an error occurred while the VX4380 was parsing a command or query. Table 4-5 on page 4-7 lists the command error messages.
6	-	Not used
7	128	Power On shows that the VX4380 was powered on.

The following example assumes that all bits have been enabled using the Event Status Enable Register (see the next section for information about this register). If a *ESR? query returns a value of 128, bit 7 (decimal value of 128) is set indicating that the instrument is in the initial power-on state.

Event Status Enable Register

The Event Status Enable Register, shown in Table 4–4, controls which events are summarized in the Event Status bit (bit 5) of the Status Byte Register. Use the *ESE command to set bits in the Event Status Enable Register. Use the *ESE? query to see what bits in the Event Status Enable Register are set. The response from this query is the sum of the decimal values for all bits summarized in the event status bit of the Status Byte Register.

Table 4–4: The Event Status Enable Register

Bit	Decimal Value	Function
0	1	Set bit 5 of the Status Byte register when bit 1 (the Operation Complete bit) of the Standard Event Status register is set.
1	2	Not used
2	4	Set bit 5 of the Status Byte register when bit 2 (the Query Error bit) of the Standard Event Status register is set.
3	8	Not used
4	16	Set bit 5 of the Status Byte register when bit 4 (the Execution Error bit) of the Standard Event Status register is set.
5	32	Set bit 5 of the Status Byte register when bit 5 (the Command Error bit) of the Standard Event Status register is set.
6	64	Not used
7	128	Set bit 5 of the Status Byte register when bit 7 (the Power On bit) of the Standard Event Status register is set.

If, for example, the *ESE? query returns a value of 255, all bits are set, indicating that all events will set the event status bit (bit 5) of the Status Byte Register.

The Output Queue

The VX4380 stores query responses in the Output queue.

The System Error and Event Queue

The VX4380 error and event messages are stored in the System Error and Event queue. Use the SYSTem:ERRor? query to get the event number and a text description of the event. Reading an event removes it from the queue. The Event queue stores detailed information for up to 10 events; the events are stored in first-in first-out order.

Status and Event Reporting Process

Figure 4–1 shows how to use the Status and Event Reporting system. In the explanation that follows, numbers in parentheses refer to the circled numbers in Figure 4–1.

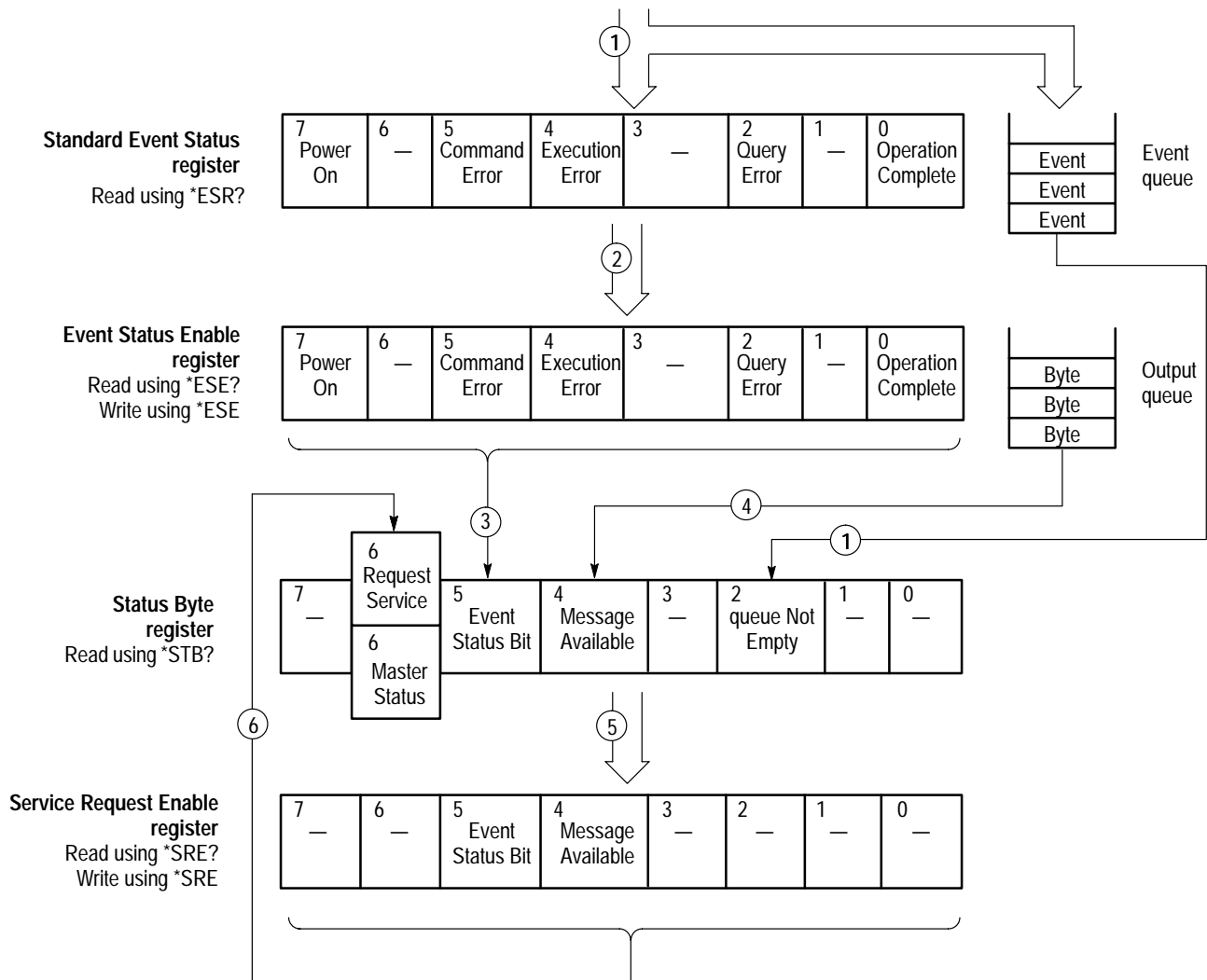

Figure 4–1: Status and Event Reporting Process

When an event occurs the appropriate bit in the Standard Event Status Register is set to one and the event is recorded in the Event queue (1). If the corresponding bit in the Event Status Enable Register is also enabled (2), then the event status bit in the Status Byte Register is set to one (3).

When output is sent to the Output queue (for example, a response to a query), the message available bit in the Status Byte Register is set to one (4).

When a bit in the Status Byte Register is set to one and the corresponding bit in the Service Request Enable Register is enabled (5), the master status summary bit in the Status Byte Register is set to one and a service request is generated (6).

Messages

The VX4380 generates error messages in response to events caused by commands or queries. Each type of event sets a specific bit in the Standard Event Status Register. Thus, each message is associated with a specific Standard Event Status Register bit. In the message tables that follow, the associated Standard Event Status Register bit is specified in the table title. Not shown in the tables are secondary messages giving more detail about the cause of the error or the meaning of the message. These secondary messages are shown for each command and query in *Syntax and Commands*.

Table 4–5 shows the error messages generated by improper command syntax. Check to see that the command is properly formatted and that it follows the rules in *Syntax and Commands*.

Table 4–5: Command Error Messages (Bit 5 in Standard Event Status Register)

Code	Message
-102	Syntax error; 2 dimensional <channel_spec> invalid for VX4350 module
-102	Syntax error; 3 dimensional <channel_spec> invalid for VX43xx module
-102	Syntax error; channel dimension mismatch
-102	Syntax error; integer field greater than 10 characters
-102	Syntax error; Missing module name
	Syntax error; Module name already defined
-102	Syntax error; Module name already defined
-102	Syntax error; Module name length greater than 12 characters
-102	Syntax error; Non-contiguous section numbers
-102	Syntax error; ROUTe:CONFIgure command invalid for VX43xx module
-102	Syntax error; ROUTe:DISJoin command invalid for VX43xx module
-102	Syntax error; ROUTe:JOIN command invalid for VX43xx module
-102	Syntax error; ROUTe:MODE command invalid for VX43xx module
-102	Syntax error; Undefined module name
-102	Syntax error; Unexpected x detected while ...

Table 4-5: Command Error Messages (Bit 5 in Standard Event Status Register) (Cont.)

Code	Message
-121	Invalid character in number
-123	Exponent too large

Table 4-6 lists the execution error messages that can occur during execution of a command. Parameter y in these error messages represents the local bus address of the module that the error message applies to. A value of 1 indicates the module containing the Option 01 daughter board, a value of 2 the module in the next slot to the right, and so on.

Table 4-6: Execution Error Messages (Bit 4 in Standard Event Status Register)

Code	Message
-200	Execution error; Reserved
-200	Execution error; scan list undefined
-211	Trigger ignored
-213	Init ignored
-222	Data out of range; Channel number x on module y
-222	Data out of range; Channel number x!x on module y
-222	Data out of range; Channel number x!x!x on module y
-222	Data out of range; Invalid module address specified
-222	Data out of range; Invalid section number
-222	Data out of range; invalid sequence count
-222	Data out of range; invalid trigger delay
-222	Data out of range; Invalid VXI TTL Trigger level
-222	Data out of range; Maximum value for ESE command is 255
-222	Data out of range; Maximum value for SRE command is 255
-222	Data out of range; invalid dwell time specified.
-223	Too much data; channel list array overflow
-223	Too much data; Input buffer overflow
-223	Too much data; Output buffer full
-223	Too much data; scan list array overflow
-240	Hardware error; shift register verification error – module m
-241	Hardware error; Unrecognized module d, d

Table 4–7 lists the device dependent error messages that can occur during VX4380 operation.

Table 4–7: Device Dependent Error Messages (Bit 3 in Standard Event Status Register)

Code	Message
-350	Queue overflow; error/event queue
-350	Queue overflow; output queue



Appendices

Appendix A: Specifications

Table A-1: VXI Instrument Characteristics

Characteristics	Description												
VXI General Characteristics	The instrument provides a VXI interface that complies with Revision 1.4. The VXI interface is defined by the VXI Consortium, Inc.												
Interface Type	Message Based (1.4)												
Protocols	Word Serial (WSP)												
TTL Outputs	VXI TTLTRG* Lines TTLTRG0* through TTLTRG7* under program control.												
Product Compliance to Regulations (VX4320, VX4330, VX4350, VX4380 only)													
Product Safety	UL listed UL 3111-1 UL listed CAN/CSA C22.2 NO.1010-1 UL classified to IEC-1010-1.												
IEC Characteristics	Overvoltage Category: CAT I Safety: Class I												
EMC	Per EC Council Directive 89/336 EEC (EC-92), the following standards and limits apply to the requirements for equipment to be used in residential, commercial, and light industrial environments. They are specified in EN-50081-1, the Generic Emission Standard, and in EN 50082-1, the Generic Immunity Standard. For equipment that is also intended to be used in industrial environments, the standards and limits specified in EN 50081-2 and EN 50082-2 should be used in addition.												
Emissions	Emissions shall be within the limits specified by the following requirements: Enclosure: EN 55011 Class A limit for radiated emissions. AC Mains: EN 55011 Class A limit for radiated emissions. EN 60555-2: Power line harmonics												
Immunity, Enclosure, Radio Frequency Electromagnetic Field; IEC 801-3	No state change when the instrument is subjected to a 3 V/M electromagnetic field over the frequency range of 27 MHz to 500 MHz.												
Immunity, Enclosure, Electrostatic Discharge (ESD); IEC 801-2	Up to 8 kV with no loss of stored data, change to control settings, degradation of performance, or temporary loss of function. No state change.												
Immunity, Fast Transients, Common Mode; IEC 801-4	No loss of stored data, change to control settings, degradation of performance, or temporary loss of function will occur when the instrument is subjected to the transients as described below.												
	<table border="1"> <thead> <tr> <th>Port</th> <th>Peak Voltage – kV</th> <th>Tr/Th – ns</th> <th>Rep. Freq. – kHz</th> </tr> </thead> <tbody> <tr> <td>Signal & control</td> <td>0.5</td> <td>5/50</td> <td>5</td> </tr> <tr> <td>AC Power</td> <td>1</td> <td>5/50</td> <td>5</td> </tr> </tbody> </table>	Port	Peak Voltage – kV	Tr/Th – ns	Rep. Freq. – kHz	Signal & control	0.5	5/50	5	AC Power	1	5/50	5
Port	Peak Voltage – kV	Tr/Th – ns	Rep. Freq. – kHz										
Signal & control	0.5	5/50	5										
AC Power	1	5/50	5										

Table A-1: VXI Instrument Characteristics

Characteristics	Description
EN 55011, Class A	The instrument complies with the requirements of EN 55011 for radiated, conducted, and magnetic emissions, when installed in a suitable VXI chassis. A suitable VXI chassis is defined as one which contains adequate EMC shielding which makes contact with the RF gasket on the front and rear shields of the VX43xx Module.
FCC	The instrument complies with the requirements of FCC CFR 47, Part 15, Subpart B, Class A for radiated and conducted emissions.

Table A-2: Environmental/Reliability Characteristics

Characteristics	Description
Temperature	
Operating	Meets or exceeds MIL-T-28800E for Type III, 0 to 50° C external ambient, when operated in a mainframe providing Class 3 equipment.
Non-operating	-40° C to +71° C Airflow of at least 1.57 liters/sec at 0.05 mm H ₂ O air pressure, -10° C/55° C for 10° C (or less) temperature rise of internal air, as measured at the cooling air exit points, and with no heat transfer either to or from any adjacent VXI modules.
Humidity	
Operating	Up to 95% at up to 30° C, and up to 45%, at up to 50° C.
Non-operating	Up to 95%, at up to 50° C.
Altitude (1) Operating	6,000 ft. altitude.
Altitude (2)	Meets or exceeds MIL-T-28800E for Type III, (operating to 10,000 ft., non-operating to 15,000 ft.). Derate maximum operating temperature above TBD ft. by degree C per 1000 ft.

Table A-3: VX4380-Specific Characteristics

Characteristics	Description
VME Interrupter Level	Switch selectable to a level between 1 and 7.
VXI Logical Address	Switch selectable to a value between 0 and 254.
VXI Dynamic Addressing	Not supported.
Contents of device/manufacture dependent VXI registers.	
ID Register	BFFD hexadecimal.
Device Type	Set according to the model number of the slave module that the interface is installed on as specified in the following table. (Convert the last 3 digits of the model number to hex, take the one's complement, AND with F7FF.)

Table A-3: VX4380-Specific Characteristics (Cont.)

Characteristics	Description	
	Slave Module Model No.	Register Contents (hexadecimal)
	VX4320	F6BF
	VX4330	F6B5
	VX4350	F6A1
	VX4380	F683
VXI TTL Trigger Outputs	One or more of the VXI TTLTRG* signals may be driven. All TTLTRG* outputs may be disabled.	
VXI TTL Trigger Inputs	One of the VXI TTLTRG* signals may be selected to be polled or to act as an interrupt source to the module's microprocessor.	
Configuration	4 4 × 16 2-wire matrices	
Current		
Voltage	+5 V Supply	
Maximum Average Current	3.90 A	
Fused	10 A	

Table A-4: Relay Switching Characteristics

Characteristics	Description			
Maximum Switching Voltages	Terminals	DC	AC/RMS	V Peak
	HI to LO	220	250	354
	HI to Chassis	250	250	354
	LO to Chassis	250	250	354
Maximum Switching Current (non-inductive)	Terminals	<30 VDC	<30 VAC/RMS	
	per channel	2 A	2 A	
	per common	2 A	2 A	
Maximum Switching Power (non-inductive)	Terminals	<220 VDC	<250 VAC/RMS	
	per channel	60 W	125 VA	
	per common	60 W	125 VA	
Rated Switching Operations	Loading	Operations		
	No Load	1×10^8		
	30 VDC 2 A	1×10^5		
	30 VDC 1 A	2×10^5		
	125 VAC 1 A	1×10^5		

Table A-5: Switching Channel Characteristics

Characteristics	Description	
Bandwidth (-3 dB) Characteristics - 50 Ω Balanced Source/Load	Circuit	Bandwidth
	1 crosspoint closed in a 4 × 16 matrix	>15 MHz (>30 MHz typical)
	1 crosspoint closed in a 16 × 16 matrix	>15 MHz (>30 MHz typical)
Channel to Channel Crosstalk/Open Channel Isolation	Frequency/Isolation	Crosstalk/Isolation
	10 K	< -80 dB
	100 kHz	< -60 dB
	1 MHz	< -40 dB

Table A-6: Signal Path

Characteristics	Description	
Signal Path Thermal Offset	Offset Voltage: <7 mV	
	Condition	Contact Resistance
	Initial	< 1.5 Ω
	After Rated Operations	< 3.5 Ω
Insulation Resistance	> 5 × 10 ⁸ Ω @ +25° C, 40% RH > 5 × 10 ⁶ Ω @ +40° C, 95% RH	

Table A-7: Cabling

Characteristics	Description
Recommended Cable	VX1660 Analog Cable, 5 meters
Cable kit	VX1630S 160-pin Connector Kit

Table A-7: Power Distribution

Characteristics	Description
+5 VDC Current	3.90 A



Appendix B: Input/Output Connections

The front panel connector pinouts for the VX4380 are shown in the tables on the following pages.

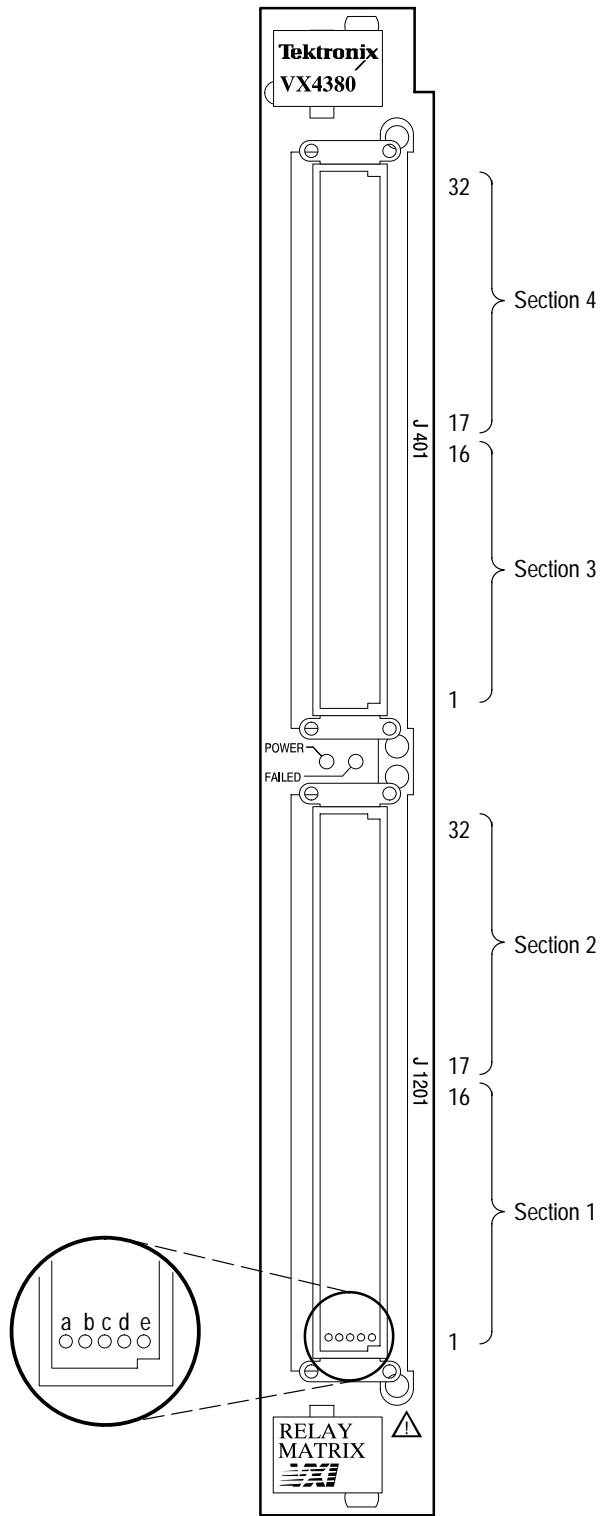

Figure B-1: VX4380 Front Panel

Table B-1: VX4380 Upper Connector (J401) Pinout

Pin No.						Sect.
32	Col16Lo	Col16Hi	Row1Lo	Col16Hi	Col16Lo	4
31	Col15Lo	Col15Hi	Row1Hi	Col15Hi	Col15Lo	4
30	Col14Lo	Col14Hi	Row2Lo	Col14Hi	Col14Lo	4
29	Col13Lo	Col13Hi	Row2Hi	Col13Hi	Col13Lo	4
28	Col12Lo	Col12Hi	Row3Lo	Col12Hi	Col12Lo	4
27	Col11Lo	Col11Hi	Row3Hi	Col11Hi	Col11Lo	4
26	Col10Lo	Col10Hi	Row4Lo	Col10Hi	Col10Lo	4
25	Col09Lo	Col09Hi	Row4Hi	Col09Hi	Col09Lo	4
24	Col08Lo	Col08Hi	Row4Hi	Col08Hi	Col08Lo	4
23	Col07Lo	Col07Hi	Row4Lo	Col07Hi	Col07Lo	4
22	Col06Lo	Col06Hi	Row3Hi	Col06Hi	Col06Lo	4
21	Col05Lo	Col05Hi	Row3Lo	Col05Hi	Col05Lo	4
20	Col04Lo	Col04Hi	Row2Hi	Col04Hi	Col04Lo	4
19	Col03Lo	Col03Hi	Row2Lo	Col03Hi	Col03Lo	4
18	Col02Lo	Col02Hi	Row1Hi	Col02Hi	Col02Lo	4
17	Col01Lo	Col01Hi	Row1Lo	Col01Hi	Col01Lo	4
16	Col16Lo	Col16Hi	Row1Lo	Col16Hi	Col16Lo	3
15	Col15Lo	Col15Hi	Row1Hi	Col15Hi	Col15Lo	3
14	Col14Lo	Col14Hi	Row2Lo	Col14Hi	Col14Lo	3
13	Col13Lo	Col13Hi	Row2Hi	Col13Hi	Col13Lo	3
12	Col12Lo	Col12Hi	Row3Lo	Col12Hi	Col12Lo	3
11	Col11Lo	Col11Hi	Row3Hi	Col11Hi	Col11Lo	3
10	Col10Lo	Col10Hi	Row4Lo	Col10Hi	Col10Lo	3
9	Col09Lo	Col09Hi	Row4Hi	Col09Hi	Col09Lo	3
8	Col08Lo	Col08Hi	Row4Hi	Col08Hi	Col08Lo	3
7	Col07Lo	Col07Hi	Row4Lo	Col07Hi	Col07Lo	3
6	Col06Lo	Col06Hi	Row3Hi	Col06Hi	Col06Lo	3
5	Col05Lo	Col05Hi	Row3Lo	Col05Hi	Col05Lo	3
4	Col04Lo	Col04Hi	Row2Hi	Col04Hi	Col04Lo	3
3	Col03Lo	Col03Hi	Row2Lo	Col03Hi	Col03Lo	3
2	Col02Lo	Col02Hi	Row1Hi	Col02Hi	Col02Lo	3
1	Col01Lo	Col01Hi	Row1Lo	Col01Hi	Col01Lo	3
Pin	a	b	c	d	e	

Table B-2: VX4380 Lower Connector (J1201) Pinout

Pin No.						Sect.
32	Col16Lo	Col16Hi	Row1Lo	Col16Hi	Col16Lo	2
31	Col15Lo	Col15Hi	Row1Hi	Col15Hi	Col15Lo	2
30	Col14Lo	Col14Hi	Row2Lo	Col14Hi	Col14Lo	2
29	Col13Lo	Col13Hi	Row2Hi	Col13Hi	Col13Lo	2
28	Col12Lo	Col12Hi	Row3Lo	Col12Hi	Col12Lo	2
27	Col11Lo	Col11Hi	Row3Hi	Col11Hi	Col11Lo	2
26	Col10Lo	Col10Hi	Row4Lo	Col10Hi	Col10Lo	2
25	Col09Lo	Col09Hi	Row4Hi	Col09Hi	Col09Lo	2
24	Col08Lo	Col08Hi	Row4Hi	Col08Hi	Col08Lo	2
23	Col07Lo	Col07Hi	Row4Lo	Col07Hi	Col07Lo	2
22	Col06Lo	Col06Hi	Row3Hi	Col06Hi	Col06Lo	2
21	Col05Lo	Col05Hi	Row3Lo	Col05Hi	Col05Lo	2
20	Col04Lo	Col04Hi	Row2Hi	Col04Hi	Col04Lo	2
19	Col03Lo	Col03Hi	Row2Lo	Col03Hi	Col03Lo	2
18	Col02Lo	Col02Hi	Row1Hi	Col02Hi	Col02Lo	2
17	Col01Lo	Col01Hi	Row1Lo	Col01Hi	Col01Lo	2
16	Col16Lo	Col16Hi	Row1Lo	Col16Hi	Col16Lo	1
15	Col15Lo	Col15Hi	Row1Hi	Col15Hi	Col15Lo	1
14	Col14Lo	Col14Hi	Row2Lo	Col14Hi	Col14Lo	1
13	Col13Lo	Col13Hi	Row2Hi	Col13Hi	Col13Lo	1
12	Col12Lo	Col12Hi	Row3Lo	Col12Hi	Col12Lo	1
11	Col11Lo	Col11Hi	Row3Hi	Col11Hi	Col11Lo	1
10	Col10Lo	Col10Hi	Row4Lo	Col10Hi	Col10Lo	1
9	Col09Lo	Col09Hi	Row4Hi	Col09Hi	Col09Lo	1
8	Col08Lo	Col08Hi	Row4Hi	Col08Hi	Col08Lo	1
7	Col07Lo	Col07Hi	Row4Lo	Col07Hi	Col07Lo	1
6	Col06Lo	Col06Hi	Row3Hi	Col06Hi	Col06Lo	1
5	Col05Lo	Col05Hi	Row3Lo	Col05Hi	Col05Lo	1
4	Col04Lo	Col04Hi	Row2Hi	Col04Hi	Col04Lo	1
3	Col03Lo	Col03Hi	Row2Lo	Col03Hi	Col03Lo	1
2	Col02Lo	Col02Hi	Row1Hi	Col02Hi	Col02Lo	1
1	Col01Lo	Col01Hi	Row1Lo	Col01Hi	Col01Lo	1
Pin	a	b	c	d	e	

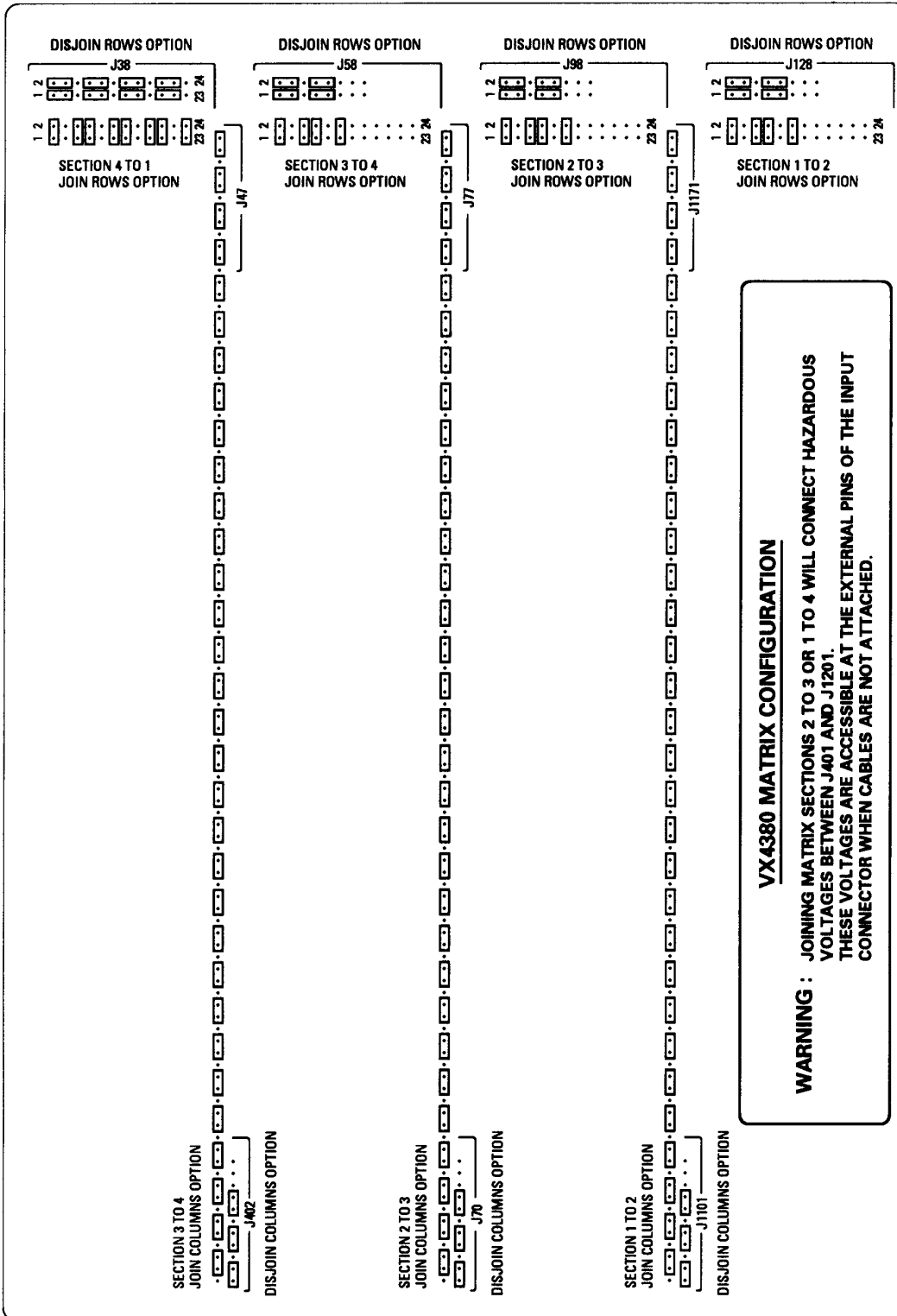

Figure B-2: Matrix Configuration

Appendix C: Examples

In these examples an Option 01 daughter board is installed on a VX4380 Module. Two additional VX4380 Modules are installed in consecutive slots to the right of the first VX4380.

Example 1

- Reset the modules. This command places the VX4380 Modules in their power-on state. All channels on all VX4380 Modules are opened. This command also clears the Output queue, Error/Event queue, and the Standard Event Status register.

```
WRITE      system:preset
```

- Reset the modules. Open all channels on all VX4380 Modules but do not clear the Output queue, the Error/Event queue, or the Standard Event Status register.

```
WRITE      *RST
```

- Clear the Output queue, the Error/Event queue, and the Standard Event Status register, but do not change the state of the VX4380 Modules.

```
WRITE      *CLS
```

- Query the default module names assigned to the modules.

```
WRITE      route:module:catalog?
```

```
READ       "M1", "M2", "M3"
```

- Close the relay that joins row 4 to column 15 in section 2 on the third VX4380.

```
WRITE      close (@m3(4!15!2))
```

- Change the module name assignments of the relay modules to "MATRIX_1", "MATRIX_2", and "MATRIX_3".

```
WRITE      mod:def matrix_1,1; def matrix_2,2; def  
matrix_3,3
```

- Query the new module names.

```
WRITE      route:module:catalog?
```

```
READ       "MATRIX_1", "MATRIX_2", "MATRIX_3"
```

- Enable VXI TTL trigger 3.

```
WRITE          output:t1ltrg3:State on
```

- Assign a close dwell time of 0.25 seconds to each of the VX4380 Modules.

```
WRITE          close:dwell m1,0.25; dwell m2,0.25; dwell
m3,0.25
```

Note that this command is equivalent to the following three commands.

```
WRITE          close:dwell m1,0.25
```

```
WRITE          close:dwell m2,0.25
```

```
WRITE          close:dwell m3,0.25
```

- Open all relays on the first and second VX4380 Modules.

```
WRITE          open:all matrix_1; all matrix_2
```

- Close the relays that join row 1 to columns 10 through 16 in section 3 of the first VX4380, the relays that join row 3 to columns 1 and 2 in section 2 of the second VX4380, and the relays that join rows 1 through 4 to column 6 in section 2 of the third VX4380. After closing these relays, wait 0.25 seconds then pulse VXI TTL trigger 3 low for 3 μ sec.

```
WRITE          close (@matrix_1(1!10!3:1!16!3),
matrix_2(3!1!2,3!2!2), matrix_3(1!6!2:4!6!2))
```

- Query the close state of the relays in section 2 of the first VX4380.

```
WRITE          close? (@matrix_1(1!1!2:4!16!2))
```

```
READ          0 0 0 0 0 0 0 0 0 0 0 0 0 0 0 0 0 0 0 0 0
0 0 0          0 0 0 0 0 1 1 0 0 0 0 0 0 0 0 0 0 0 0 0 0
0 0 0          0 0 0 0 0 0 0 0 0 0
```

- The close states are returned in the same order in which they are specified in the close query. In this example the specified order is:

```
1!1!2,1!2!2,1!3!2, ..., 1!16!2
```

```
2!1!2,2!2!2,2!3!2, ..., 2!16!2
```

```
3!1!2,3!2!2,3!3!2, ..., 3!16!2
```

```
4!1!2,4!2!2,4!3!2, ..., 4!16!2
```

Note that this query is equivalent to the following close query:

```
close? (@matrix_1(65:128))
```

- Define a scan sequence consisting of the relays that join row 1 to columns 1 through 16 in section 3 of the second VX4330. Note that this command causes all relays in the scan list to be opened.

```
WRITE          scan (@matrix_2(1!1!3:1!16!3))
```

- Set the trigger source for the defined scan list to “immediate”. This causes the Option 01 daughter board to generate its own internal triggers. Each time a trigger is generated, the following sequence of events occurs:

Wait for the trigger delay defined by the TRIGger[:SEQuence]:DELay command to expire.

Open the relay in the scan list that is currently closed.

Wait for the open dwell time assigned to the module containing the relay just opened to expire.

Close the next relay in the scan list.

Wait for the close dwell time assigned to the module containing the relay just closed to expire.

Pulse any enabled VXI TTL triggers low for 3 μ sec.

In this case, the default trigger delay of 0 is used, the default open dwell time of 0 is used, and the close dwell time has been set to 0.25 seconds. Note that the second and third events are skipped when the first trigger is received. The last three events are skipped when the last trigger is received. Triggers are not recognized until an INITiate[:IMMediate] or an INITiate:Continuous command is received.

- Set the number of times to scan through the defined scan list to 2, to begin when an INITiate[:IMMediat] command is received.

```
WRITE          trigger:sequence:count 2
```

- Scan through the entire scan list two times.

```
WRITE          initiate
```

- Set the Operation Complete bit in the Standard Event Status register after the scan list has been sequenced two times.

```
WRITE          *opc
```

- Poll the Operation Complete bit in the Standard Event Status register to see when the scan sequence is finished.

```
WRITE          *esr?
```

```
READ          <nr1>
```

The <nr1> response is a 3-digit ASCII-encoded integer. If the value of this number is odd, the Operation Complete bit is set.

- Scan through the entire scan list repeatedly until an ABORt command is received.

```
WRITE          initiate:continuous
```

- Stop sequencing through the scan list. Open the relay that was closed last.

```
WRITE          abort
```

Example 2

- Make sure that all of the crosspoint relays are open.

```
WRITE          ROUTE:OPEN:ALL M1
```

- Close the 2-wire connection between row 1 and column 1 of section 1.

```
WRITE          ROUTE:CLOSE (@M1(1!1!1))
```

- Close the 2-wire connection between row 2 and column 7 of section 3.

```
WRITE          ROUTE:CLOSE (@M1(2!7!3))
```

- Open the 2-wire connection between row 1 and column 1 of section 1.

```
WRITE          ROUTE:OPEN (@M1(1!1!1))
```

- Check for system errors.

```
WRITE          SYSTEM:ERR?
```

```
READ           0, "No error"
```

Appendix D: User Service

This appendix contains service-related information for the VX4380 that covers the following topics:

- Performance verification
- Preventive maintenance
- Troubleshooting
- User-replaceable parts

Performance Verification

You may use the Operational Check procedure listed in Getting Started to verify that the module is operating correctly. The instrument has been fully tested and calibrated before leaving the factory.

If the self test or diagnostic commands indicate a failure, contact your Tektronix field office or representative for assistance.

Preventive Maintenance

You should perform inspection and cleaning as preventive maintenance. Preventive maintenance, when done regularly, may prevent VX4380 malfunction and enhance reliability. Inspect and clean the VX4380 as often as conditions require by following these steps:

1. Turn off power and remove the VX4380 from the VXIbus mainframe.
2. Remove loose dust on the outside of the instrument with a lint-free cloth.
3. Remove any remaining dirt with a lint-free cloth dampened with water or a 75% isopropyl alcohol solution. Do not use abrasive cleaners.

Troubleshooting

If you suspect a malfunction, first double check connections to and from the VX4380. If the trouble persists, perform the *Functional Check*.

If the self test indicates a failure, contact your Tektronix field office or representative for assistance.

User-Replaceable Parts

Refer to *Appendix E* for replaceable parts information.

Appendix E: Replaceable Parts

This section contains a list of the replaceable modules for the <instrument>. Use this list to identify and order replacement parts.

Parts Ordering Information

Replacement parts are available through your local Tektronix field office or representative.

Changes to Tektronix products are sometimes made to accommodate improved components as they become available and to give you the benefit of the latest improvements. Therefore, when ordering parts, it is important to include the following information in your order.

- Part number
- Instrument type or model number
- Instrument serial number
- Instrument modification number, if applicable

If you order a part that has been replaced with a different or improved part, your local Tektronix field office or representative will contact you concerning any change in part number.

Change information, if any, is located at the rear of this manual.

Module Servicing

Modules can be serviced by selecting one of the following three options. Contact your local Tektronix service center or representative for repair assistance.

Module Exchange. In some cases you may exchange your module for a remanufactured module. These modules cost significantly less than new modules and meet the same factory specifications. For more information about the module exchange program, call 1-800-TEK-WIDE, extension 6630.

Module Repair and Return. You may ship your module to us for repair, after which we will return it to you.

New Modules. You may purchase replacement modules in the same way as other replacement parts.

Using the Replaceable Parts List

This section contains a list of the mechanical and/or electrical components that are replaceable for the <instrument>. Use this list to identify and order replacement parts. The following table describes each column in the parts list.

Parts List Column Descriptions

Column	Column Name	Description
1	Figure & Index Number	Items in this section are referenced by figure and index numbers to the exploded view illustrations that follow.
2	Tektronix Part Number	Use this part number when ordering replacement parts from Tektronix.
3 and 4	Serial Number	Column three indicates the serial number at which the part was first effective. Column four indicates the serial number at which the part was discontinued. No entries indicates the part is good for all serial numbers.
5	Qty	This indicates the quantity of parts used.
6	Name & Description	An item name is separated from the description by a colon (:). Because of space limitations, an item name may sometimes appear as incomplete. Use the U.S. Federal Catalog handbook H6-1 for further item name identification.
7	Mfr. Code	This indicates the code of the actual manufacturer of the part.
8	Mfr. Part Number	This indicates the actual manufacturer's or vendor's part number.

Abbreviations Abbreviations conform to American National Standard ANSI Y1.1–1972.

Mfr. Code to Manufacturer Cross Index The table titled Manufacturers Cross Index shows codes, names, and addresses of manufacturers or vendors of components listed in the parts list.

Manufacturers Cross Index

Mfr. Code	Manufacturer	Address	City, State, Zip Code
0KB01	STAUFFER SUPPLY CO	810 SE SHERMAN	PORTLAND, OR 97214-4657
0KB05	NORTH STAR NAMEPLATE INC	5750 NE MOORE COURT	HILLSBORO, OR 97124-6474
22526	BERG ELECTRONICS INC	857 OLD TRAIL ROAD	ETTERS, PA 17319
30817	INSTRUMENT SPECIALTIES CO INC	EXIT 53, RT 80 BOX A	DELAWARE WATER GAP, PA 18327
61857	SAN-O INDUSTRIAL CORP	91-3 COLIN DRIVE	HOLBROOK, NY 11741
80009	TEKTRONIX INC	14150 SW KARL BRAUN DR PO BOX 500	BEAVERTON, OR 97077-0001
93907	CAMCAR DIV OF TEXTRON INC	ATTN: ALICIA SANFORD 516 18TH AVE	ROCKFORD, IL 611045181
TK1943	NEILSEN MANUFACTURING INC	3501 PORTLAND RD NE	SALEM, OR 97303
TK2548	XEROX CORPORATION	DIV OF XEROX CORPORATION 14181 SW MILLIKAN WAY	BEAVERTON, OR 97005
TK2647	INSTRUMENT SPECIALTIES INC	C/O TEMCO NW 1336 SE 51ST STREET	HILLSBORO, OR 97123

Replaceable Parts List

Fig. & Index Number	Tektronix Part Number	Serial No. Effective	Serial No. Discont'd	Qty	Name & Description	Mfr. Code	Mfr. Part Number
	070-9182-XX			1	MANUAL,TECH:USERS	80009	070-9182-XX
	070-9202-XX			1	MANUAL,TECH:REFERENCE GUIDE	TK2548	070-9202-XX
1	334-8951-00			1	MARKER,IDENT:MARKED VX4380	0KB05	334-8951-00
2	367-0411-00			1	HANDLE,EJECTOR:TOP,SINGLE WIDE		20817-328
3	950-4827-00			2	SCREW PHIL M 2.5 X 8 CSK	0KB01	950-4827-00
4	950-4448-00			2	SCREW M2.5X10 CHEESEHEAD	80009	950-4448-00
5	950-3794-00			2	WAVY 2.7MM	80009	950-3794-00
6	159-0193-00			1	FUSE,WIRE LEAD:10A,60V,FAST BLOW,5 SEC,	61857	SP5-10A
7	163-0384-00			1	IC,DIGITAL:CMOS,PRGM	80009	163-0384-00
8	386-6862-00			1	PANEL,VXI:END CAP,VXI APPLICATION	TK1943	386-6862-00
9	348-1434-00			4	GASKET,EMI:2.912 L,CLIP ON,BE CU EMI GASKET,TIN PLATED	30817	97-613-17-029
10	211-0373-00			7	SCREW,MACHINE:4-40 X 0.250,PNH,STL,CDPL,T-10	93907	ORDER BY DESCRIPTION
11	200-4231-00			1	COVER:VXI APPLICATION	TK1943	200-4231-00
12	334-8971-00			1	MARKER,IDENT:MATRIX CONFIGURATION LABEL,VX4380	0KB05	334-8971-00
13	131-3199-00			128	CONN,SHUNT:SHUNT,FEMALE,STR,1 X 2,0.1 CTR	22526	68786-202
14	367-0410-00			1	HANDLE,EJECTOR:BOTTOM,SINGLE WIDE MODULE		20817-327
15	211-0391-00			5	SCR,ASSEM,WSHR:2-56 X 0.437, PNH,STL,CDPL,T-8	93907	ORDER BY DESCRIPTION
16	334-8952-00			1	MARKER,IDENT:MARKED VXIBUS & RELAY MATRIX	0KB05	334-8952-00
17	351-0984-00			2	GUIDE:BOTTOM GUIDE,5 ROW	TK1943	351-0984-00
18	351-0983-00			2	GUIDE:TOP GUIDE,5 ROW	TK1943	351-0983-00
19	348-1365-01			1	SHLD GSKT,ELEC:SYMETRICAL SLOTTED FINGER MTG,SNAP-IN	TK2647	348-1365-01
20	214-4692-01			1	KEY:VXI,TTL	80009	214-4692-01

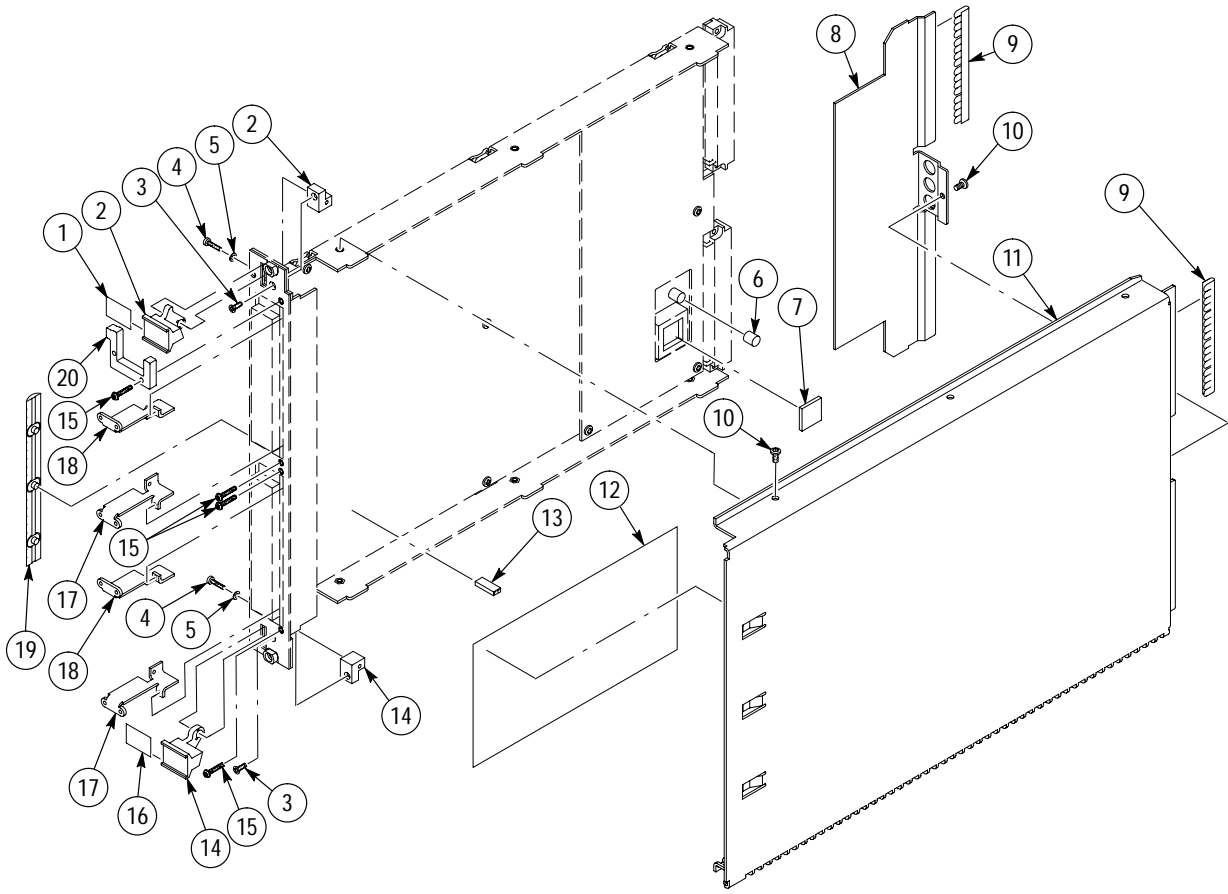

Figure E-1: VX4380 Exploded View



Glossary and Index

Glossary

The terms in this glossary are defined as used in the VXIbus System. Although some of these terms may have different meanings in other systems, it is important to use these definitions in VXIbus applications. Terms which apply only to a particular instrument module are noted. Not all terms appear in every manual.

Accessed Indicator

An amber LED indicator that lights when the module identity is selected by the Resource Manager module, and flashes during any I/O operation for the module.

ACFAIL*

A VMEbus backplane line that is asserted under these conditions: 1) by the mainframe Power Supply when a power failure has occurred (either AC line source or power supply malfunction), or 2) by the front panel ON/STANDBY switch when switched to STANDBY.

Asynchronous Communication

Communications that occur outside the normal “command-response” cycle. Such communications have higher priority than synchronous communication.

Backplane

The printed circuit board that is mounted in a VXIbus mainframe to provide the interface between VXIbus modules and between those modules and the external system.

Bus Arbitration

In the VMEbus interface, a system for resolving contention for service among VMEbus Master devices on the VMEbus.

Bus Timer

A functional module that measures the duration of each data transfer on the Data Transfer Bus (DTB) and terminates the DTB cycle if the duration is excessive. Without the termination capability of this module, a Bus Master attempt to transfer data to or from a non-existent Slave location could result in an infinitely long wait for the Slave response.

Client

In shared memory protocol (SMP), that half of an SMP channel that does not control the shared memory buffers.

CLK10

A 10 MHz, ± 100 ppm, individually buffered (to each module slot), differential ECL system clock that is sourced from Slot 0 and distributed to

Slots 1–12 on P2. It is distributed to each module slot as a single source, single destination signal with a matched delay of under 8 ns.

Commander

In the VXIbus interface, a device that controls another device (a servant). A commander may be a servant of another commander.

Command

A directive to a device. There are three types of commands:

In Word Serial Protocol, a 16-bit imperative to a servant from its commander.

In Shared Memory Protocol, a 16-bit imperative from a client to a server, or vice versa.

In a Message, an ASCII-coded, multi-byte directive to any receiving device.

Communication Registers

In word serial protocol, a set of device registers that are accessible to the commander of the device. Such registers are used for inter-device communications, and are required on all VXIbus message-based devices.

Configuration Registers

A set of registers that allow the system to identify a (module) device type, model, manufacturer, address space, and memory requirements. In order to support automatic system and memory configuration, the VXIbus standard specifies that all VXIbus devices have a set of such registers, all accessible from P1 on the VMEbus.

C-Size Card

A VXIbus instrument module that is 340.0 mm × 233.4 mm × 30.48 mm (13.4 in. × 9.2 in × 1.2 in).

Custom Device

A special-purpose VXIbus device that has configuration registers so as to be identified by the system and to allow for definition of future device types to support further levels of compatibility.

Data Transfer Bus

One of four buses on the VMEbus backplane. The Data Transfer Bus allows Bus Masters to direct the transfer of binary data between Masters and Slaves.

DC SUPPLIES Indicator

A red LED indicator that illuminates when a DC power fault is detected on the backplane.

Device Specific Protocol

A protocol for communication with a device that is not defined in the VXIbus specification.

D-Size Card

A VXIbus instrument module that is 340.0 × 366.7 mm × 30.48 mm (13.4 × 14.4 in × 1.2 in).

DTB

See Data Transfer Bus.

DTB Arbiter

A functional module that accepts bus requests from Requester modules and grants control of the DTB to one Requester at a time.

DUT

Device Under Test.

ECLTRG

Six single-ended ECL trigger lines (two on P2 and four on P3) that function as inter-module timing resources, and that are bussed across the VXIbus subsystem backplane. Any module, including the Slot 0 module, may drive and receive information from these lines. These lines have an impedance of 50 Ω; the asserted state is logical High.

Embedded Address

An address in a communications protocol in which the destination of the message is included in the message.

ESTST

Extended SStart/SStop protocol; used to synchronize VXIbus modules.

Extended Self Test

Any self test or diagnostic power-on routine that executes after the initial kernel self test program.

External System Controller

The host computer or other external controller that exerts overall control over VXIbus operations.

FAILED Indicator

A red LED indicator that lights when a device on the VXIbus has detected an internal fault. This might result in the assertion of the SYSFAIL* line.

IACK Daisy Chain Driver

The circuit that drives the VMEbus Interrupt Acknowledge daisy chain line that runs continuously through all installed modules or through jumpers across the backplane.

ID-ROM

An NVRAM storage area that provides for non-volatile storage of diagnostic data.

Instrument Module

A plug-in printed circuit board, with associated components and shields, that

may be installed in a VXIbus mainframe. An instrument module may contain more than one device. Also, one device may require more than one instrument module.

Interface Device

A VXIbus device that provides one or more interfaces to external equipment.

Interrupt Handler

A functional module that detects interrupt requests generated by Interrupters and responds to those requests by requesting status and identity information.

Interrupter

A device capable of asserting VMEbus interrupts and performing the interrupt acknowledge sequence.

IRQ

The Interrupt ReQuest signal, which is the VMEbus interrupt line that is asserted by an Interrupter to signify to the controller that a device on the bus requires service by the controller.

Local Bus

A daisy-chained bus that connects adjacent VXIbus slots.

Local Controller

The instrument module that performs system control and external interface functions for the instrument modules in a VXIbus mainframe or several mainframes. See Resource Manager.

Local Processor

The processor on an instrument module.

Logical Address

The smallest functional unit recognized by a VXIbus system. It is often used to identify a particular module.

Mainframe

Card Cage. For example, the Tektronix VX1410 Intelliframe, an operable housing that includes 13 C-size VXIbus instrument module slots.

Memory Device

A storage element (such as bubble memory, RAM, and ROM) that has configuration registers and memory attributes (such as type and access time).

Message

A series of data bytes that are treated as a single communication, with a well defined terminator and message body.

Message Based Device

A VXIbus device that supports VXI configuration and communication registers. Such devices support the word serial protocol, and possibly other message-based protocols.

MODID Lines

Module/system identity lines.

Physical Address

The address assigned to a backplane slot during an access.

Power Monitor

A device that monitors backplane power and reports fault conditions.

P1

The top-most backplane connector for a given module slot in a vertical mainframe. The left-most backplane connector for a given slot in a horizontal mainframe.

P2

The bottom backplane connector for a given module slot in a vertical C-size mainframe; or the middle backplane connector for a given module slot in a vertical D-size mainframe such as the VX1500.

Query

A form of command that allows for inquiry to obtain status or data.

READY Indicator

A green LED indicator that lights when the power-on diagnostic routines have been completed successfully. An internal failure or failure of +5 V power will extinguish this indicator.

Register Based Device

A VXIbus device that supports VXI register maps, but not high level VXIbus communication protocols; includes devices that are register-based servant elements.

Requester

A functional module that resides on the same module as a Master or Interrupt Handler and requests use of the DTB whenever its Master or Interrupt Handler requires it.

Resource Manager

A VXIbus device that provides configuration management services such as address map configuration, determining system hierarchy, allocating shared system resources, performing system self test diagnostics, and initializing system commanders.

Self Calibration

A routine that verifies the basic calibration of the instrument module circuits, and adjusts this calibration to compensate for short- and long-term variables.

Self Test

A set of routines that determine if the instrument module circuits will

perform according to a given set of standards. A self test routine is performed upon power-on.

Servant

A VXIbus message-based device that is controlled by a commander.

Server

A shared memory device that controls the shared memory buffers used in a given Shared Memory Protocol channel.

Shared Memory Protocol

A communications protocol that uses a block of memory that is accessible to both client and server. The memory block operates as a message buffer for communications.

Slot 0 Controller

See Slot 0 Module. Also see Resource Manager.

Slot 0 Module

A VXIbus device that provides the minimum VXIbus slot 0 services to slots 1 through 12 (CLK10 and the module identity lines), but that may provide other services such as CLK100, SYNC100, STARBUS, and trigger control.

SMP

See Shared Memory Protocol.

STARX

Two (2) bi-directional, 50 Ω , differential ECL lines that provide for inter-module asynchronous communication. These pairs of timed and matched delay lines connect slot 0 and each of slots 1 through 12 in a mainframe. The delay between slots is less than 5 ns, and the lines are well matched for timing skew.

STARY

Two (2) bi-directional, 50 Ω , differential ECL lines that provide for inter-module asynchronous communication. These pairs of timed and matched delay lines connect slot 0 and each of slots 1 through 12 in a mainframe. The delay between slots is less than 5 ns, and the lines are well matched for timing skew.

STST

STart/STop protocol; used to synchronize modules.

SYNC100

A Slot 0 signal that is used to synchronize multiple devices with respect to a given rising edge of CLK100. These signals are individually buffered and matched to less than 2 ns of skew.

Synchronous Communications

A communications system that follows the “command-response” cycle

model. In this model, a device issues a command to another device; the second device executes the command; then returns a response. Synchronous commands are executed in the order received.

SYSFAIL*

A signal line on the VMEbus that is used to indicate a failure by a device. The device that fails asserts this line.

System Clock Driver

A functional module that provides a 16 MHz timing signal on the Utility Bus.

System Hierarchy

The tree structure of the commander/servant relationships of all devices in the system at a given time. In the VXibus structure, each servant has a commander. A commander may also have a commander.

Test Monitor

An executive routine that is responsible for executing the self tests, storing any errors in the ID-ROM, and reporting such errors to the Resource Manager.

Test Program

A program, executed on the system controller, that controls the execution of tests within the test system.

Test System

A collection of hardware and software modules that operate in concert to test a target DUT.

TTLTRG

Open collector TTL lines used for inter-module timing and communication.

VXibus Subsystem

One mainframe with modules installed. The installed modules include one module that performs slot 0 functions and a given complement of instrument modules. The subsystem may also include a Resource Manager.

Word Serial Protocol

A VXibus word oriented, bi-directional, serial protocol for communications between message-based devices (that is, devices that include communication registers in addition to configuration registers).

Word Serial Communications

Inter-device communications using the Word Serial Protocol.

WSP

See Word Serial Protocol.

10-MHz Clock

A 10 MHz, ± 100 ppm timing reference. Also see CLK10.

488-To-VXIbus Interface

A message based device that provides for communication between the IEEE-488 bus and VXIbus instrument modules.

Index

A

Accessories, 1–5
ARM, 3–16

C

*CLS, 3–53
command, 3–18, 3–22, 3–23, 3–26, 3–30, 3–35,
3–36, 3–37, 3–41, 3–45, 3–49
Command Descriptions
ARM, 3–16
command, 3–18, 3–22, 3–23, 3–26, 3–30, 3–35,
3–36, 3–37, 3–41, 3–45, 3–49
command error messages, 4–6
Command Syntax, 3–1
Syntax Example, 3–3
Commands. *See* individual command names
Configuration Registers, 2–3

D

device dependent error messages, 4–8

E

error messages, 4–6
command errors, 4–6
device dependent errors, 4–8
execution errors, 4–7
*ESE, 3–53, 4–4
*ESE?, 3–53, 4–4
*ESR?, 3–53, 4–3
Event handling, 4–1
Event Reporting Process, 4–5
Event Reporting System, 4–1
Event Status Enable Register, 4–4
execution error messages, 4–7

F

Fast Handshake Mode, 2–3
Fuses, 1–4, 1–5

I

*IDN?, 3–54
IEEE 488.2 Commands
*CLS, 3–53
*ESE, 3–53
*ESR?, 3–53

*IDN?, 3–54
*OPC, 3–55
*OPC?, 3–55
*RST, 3–55
*SRE, 3–56
*SRE?, 3–56
*STB?, 3–57
*TST?, 3–58, 3–59
*WAI, 3–59
*ESE?, 3–53
IEEE-488 Address, 1–7

M

Maintenance, Preventive, D–1
Message, Handling, 4–1
messages. *See* error messages

N

Normal Transfer Mode, 2–2

O

*OPC, 3–55
OPC bit, 4–3
*OPC?, 3–55
Output queue, 4–4

Q

Queue
Output, 4–4
System Error and Event, 4–4

R

Register
Event Status Enable, 4–4
Service Request Enable, 4–2
Standard Event Status, 4–3
Status Byte, 4–1
Replaceable Parts, E–1
*RST, 3–55

S

Service Request Enable Register, 4–2
Specifications, A–1
*SRE, 3–56, 4–2

- *SRE?, 3–56, 4–2
- Standard Event Status Register, 4–3
- Status, 4–1
- Status and Event Reporting Process, 4–5
- Status and Event Reporting System, 4–1
- Status Byte Register, 4–1
- *STB?, 3–57, 4–1
- Switches, 1–5
 - Logical Address Switches, 1–7, 1–8
- SYSFAIL*, 1–13
- System Error and Event queue, 4–4
- SYSTem:ERROR?, 4–4

T

- Troubleshooting the VX4380, D–1
- *TST?, 3–58, 3–59

W

- *WAI, 3–59

